

LODESTAR® D8+ TÜV SÜD CERTIFIED

ELECTRIC CHAIN MOTOR

CAPACITIES

1/2 -2 ton

LIFT

Up to 184 feet

SPEED

8 - 64 ft/min

VOLTAGES

3 phase available

The Lodestar D8+ meets all current standard requirements. It's clutch, outside the load path, acts as a precise overload device; and design factor is 8:1 with a double brake installed.

The Lodestar D8+ is in accordance with 2018 igvw SQP2 as well as TÜV SÜD certified.

BENEFITS & FEATURES
IP66 RATING

An Ingress Protection (IP) Rating of 66 indicates that the Lodestar offers protection from dust and high pressure water - making this unit ideal for use in outdoor environments.

CLUTCH

Clutch outside of gear train meets international standards. Designed to prevent damage to the hoist by preventing excessive overloads.

5 POCKET LIFT WHEEL

For quiet & smooth operation.

PRECISION HELICAL GEARING

Designed for long life and smoother operation.

REDESIGNED CONTROL PANEL

Provides easier access.

HEAVY DUTY DC BRAKE

Designed for long service life, the brake location allows for quick access and easy inspection.

LOW VOLTAGE CONTROL

110 Volt for long cable runs without voltage drop. 24 and 48 volt optional.

DUTY CYCLE

H-4 duty rated for heavy duty application.

ELECTRICAL

Finger safe wiring meets all electrical codes Quick change plugs allow for voltages 230 through 460. Prevents improper voltage connections which can cause hoist damage.

ADJUSTABLE LIMIT SWITCH

Adjustable limit switch that automatically stops the hook at any predetermined point when lifting or lowering, preventing overtravel.

METRIC RATED LOAD CHAIN

Designed and manufactured by Columbus McKinnon. Zinc plated to protect against corrosion. Black phosphate finish optional.

METRIC RATED MEETS REQUIREMENTS

Meets or exceeds all world standards.

ROAD READY

Easy to stow and travel.

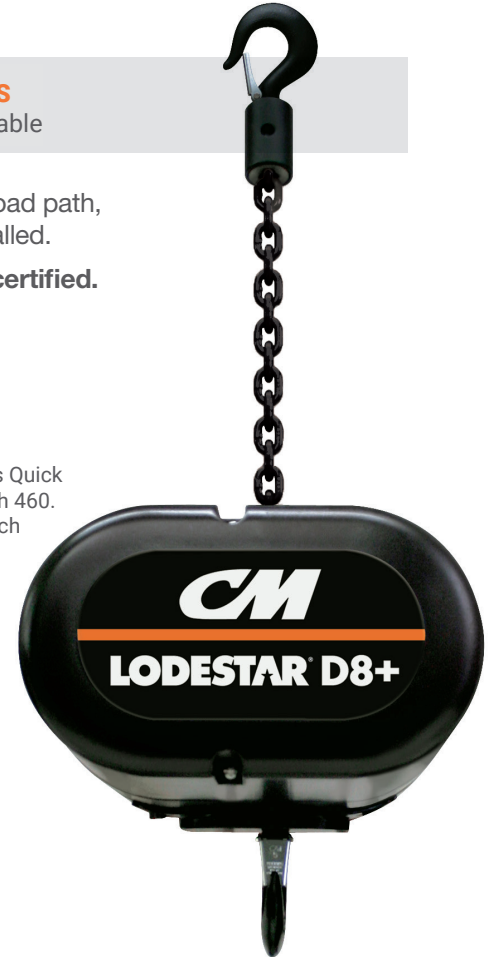
THE INDUSTRY'S BEST LIFETIME WARRANTY

SPECIFICATIONS

Model	Load Capacity	Lifting Speed fpm (mpm)	Operating Voltage	FEM Class	Chain Weight/Model Length of Lift		Load Chain EN 818-7	Full Load Amps	Reeving	Motor hp (kW)	Protection Class
	Tons (kg)				lb/ft	kg/m	in(mm)				
F	1/2 (500)	16 (4.9)	230/460-3-60	2m	0.59	0.87	1/4 (6.3)	2.2/1.3	1	0.5 (0.4)	IP66
J	1/2 (500)	32 (9.7)	230/460-3-60	2m	0.94	1.40	5/16 (7.9)	3.7/2.2	1	1 (0.75)	IP66
JJ	1/2 (500)	64 (19.5)	230/460-3-60	2m	0.94	1.40	5/16 (7.9)	7.9/5.0	1	2 (1.5)	IP66
L	1 (1000)	16 (4.9)	230/460-3-60	2m	0.94	1.40	5/16 (7.9)	3.7/2.2	1	1 (0.75)	IP66
LL	1 (1000)	32 (9.7)	230/460-3-60	2m	0.94	1.40	5/16 (7.9)	7.9/5.0	1	2 (1.5)	IP66
R	2 (2000)	8 (2.4)	230/460-3-60	2m	1.88	2.80	5/16 (7.9)	3.7/2.2	2	1 (0.75)	IP66
RR	2 (2000)	16 (4.9)	230/460-3-60	2m	1.88	2.80	5/16 (7.9)	7.9/5.0	2	2 (1.5)	IP66

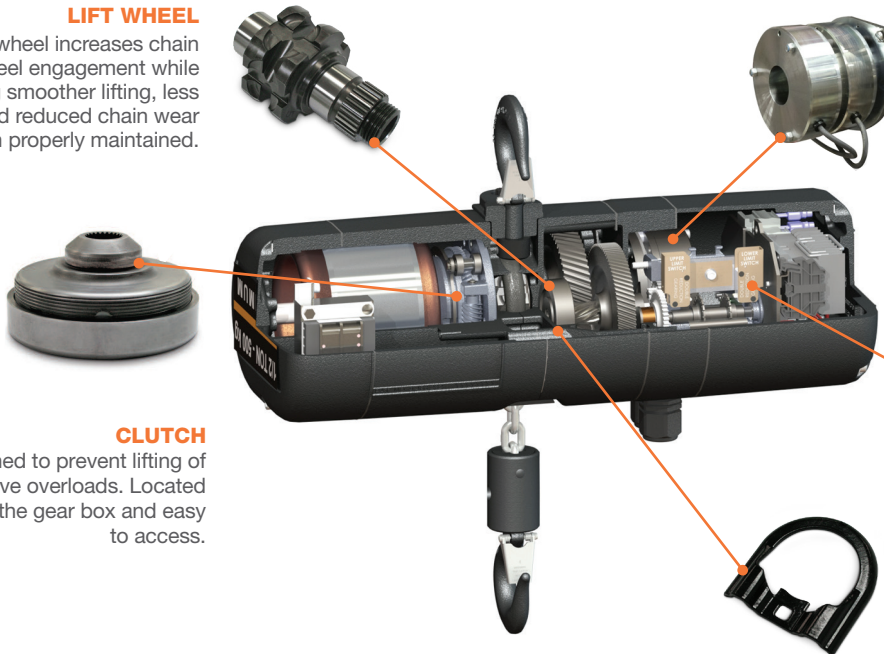
LIFT WHEEL
5 Pocket liftwheel increases chain and liftwheel engagement while providing smoother lifting, less vibration and reduced chain wear when properly maintained.



BRAKE
Heavy duty double DC brake.

LIMIT SWITCH
Adjustable limit switch that will automatically stop the hook at any predetermined point when either lifting or lowering.

CLUTCH
Designed to prevent lifting of excessive overloads. Located outside the gear box and easy to access.

INTERNAL CHAIN GUIDE
Stamped steel guide coated for corrosion resistance and quiet operation, while keeping the load chain and liftwheel aligned.

DIMENSIONS

Drawing Legend	Dimensions in (mm)		
	D8+ Series F	D8+ Series J, JJ, L, LL	D8+ Series R, RR
A	16.90 (429)	19.53 (496)	25.10 (638)
B	7.91 (201)	7.60 (193)	7.60 (193)
C	0.72 (18)	0.85 (21)	1.13 (29)
D	11.72 (298)	10.02 (255)	10.02 (255)
F	8.86 (225)	12.98 (330)	12.98 (330)
H	0.98 (25)	1.12 (28)	1.52 (39)
I	4.45 (113)	6.99 (178)	6.92 (176)
J	4.45 (113)	5.63 (143)	5.70 (145)
M	1.17 (30)	1.25 (32)	1.50 (38)
P	6.6 (168)	8.19 (208)	8.19 (208)

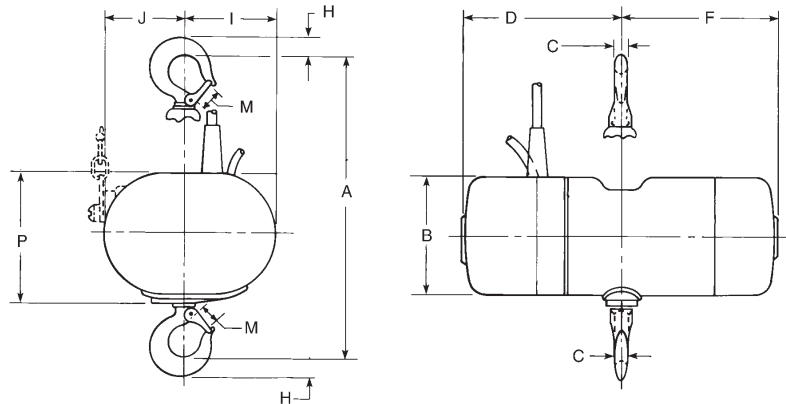

OPTIONAL FEATURES

INTEGRATED LOADCELL

DOUBLE LIMIT SWITCH

Adjustable screw limit switch that will automatically stop the hook at any predetermined point when either lifting or lowering.

CHAIN BAGS

Cloth type bags are durable and easy to mount.

DIRECT CONTROL UNITS

The CM Lodestar is available as a Direct Control Unit featuring a single cable. Direct Control Units can be used as part of a system with multiple units with a single control. The Lodestar is compatible with most Direct Control Motor Controllers.