

COFFING®

HOISTS

OPERATING & MAINTENANCE INSTRUCTIONS WITH PARTS LIST

Publication Part No. WR-5-680

WR-5 - Trolleys Electric Wire Rope Hoist

For Capacities:

3 & 5 Ton

IMPORTANT—CAUTION

To safeguard against the possibility of personal injury or property damage, follow the recommendations and instructions of this manual. This manual contains important information for the correct installation, operation, and maintenance of this equipment. All persons involved in the installation, operation, and maintenance of this equipment should be thoroughly familiar with the contents of this manual. Keep this manual for reference and further use.

⚠ WARNING

To prevent personal injury, do not use the equipment shown in this manual to lift, support, or otherwise transport people, or to suspend unattended loads over people.

TABLE OF CONTENTS

SECTION I	INTRODUCTION	
1-1	General Information	1
1-2	Safety Standards	1
1-3	Hoist Construction and Features	1
1-4	Basic Hoist Data	1
1-5	Application Information	1
1-6	Warranty	1
SECTION II	INSTALLATION	
2-1	Safety Notes	2
2-2	Trolley Installation	2
2-3	Power Supply Connection	2
2-4	Vented Transmission	2
2-5	Wire Rope Lubrication	2
2-6	Testing	2
SECTION III	OPERATION	
3-1	General	4
3-2	Safety Notes	4
3-3	Handling the Load	4
3-4	Overload Limiting Protection	4
SECTION IV	INSPECTION	
4-1	General	5
4-2	Frequent Inspection	5
4-3	Periodic Inspection	5
4-4	Load Brake Function Check	7
4-5	Wire Rope Inspection	8
4-6	Hook Throat Opening	8
SECTION V	MAINTENANCE AND REPAIR	
5-1	General	9
5-2	Limit Switch Adjustment	9
5-3	Motor Brake Adjustment	9
5-4	Wire Rope Replacement	10
5-5	Lubrication	11
SECTION VI	TROUBLESHOOTING	
6-1	General	12
SECTION VII	WIRING	
7-1	Voltage Conversion	14
7-2	Wiring Diagrams	14
SECTION VIII	ILLUSTRATED PARTS LISTS	
8-1	General	20
8-2	How to Use the Parts List	20
8-3	How to Order Replacement Parts	20
FIGURE 8-1.	Hoist Motor	21
FIGURE 8-2.	Drum Area (20 ft. lift)	22
FIGURE 8-3.	Bottom Block	24
FIGURE 8-4.	Hoist Transmission	26
FIGURE 8-5.	Control Panel (115V Control)	28
FIGURE 8-6.	Motor Brake	30
FIGURE 8-7.	Limit Switch	32
FIGURE 8-8A.	Pushbutton (Single Speed Hoists)	34
FIGURE 8-8B.	Pushbutton (Two Speed Hoists)	36
FIGURE 8-8C.	Pushbutton (Single Speed Hoist, Single Speed Trolley).....	38
FIGURE 8-8D.	Pushbutton (Two Speed Hoist, Single Speed Trolley; Single Speed Hoist, Two Speed Trolley)	40
FIGURE 8-8E.	Pushbutton (Two Speed Hoist, Two Speed Trolley)	42
FIGURE 8-9.	Trolley	44
FIGURE 8-10.	Trolley Transmission	46
FIGURE 8-11.	Trolley Motor	47
FIGURE 8-12.	Geared Trolley.....	48
SECTION IX	DO'S AND DO NOT'S	49

SECTION I INTRODUCTION

1-1. General Information

This manual provides information for the safe operation and maintenance of Coffing® WR-5 Series Hoists. All persons operating or maintaining these hoists should be familiar with the information contained herein. Adherence to the precautions, procedures and maintenance practices described should ensure long, reliable operation. Suggestions for improvements to this manual are solicited.

1-2. Safety Standards

All persons concerned with the installation, operation, inspection and maintenance of these hoists are urged to read American National Standard (ANSI) B30.16. That Standard contains valuable guidelines concerning practices designed to minimize hazards associated with the use of overhead hoisting equipment. ANSI B30.16 also contains detailed procedures for establishing hoist inspection and maintenance programs and can be of significant assistance in maintaining compliance with OSHA regulations.

1-3. Hoist Construction and Features

This hoist has a steel drum and center frame for strength in the load-bearing areas. A strong, lightweight aluminum alloy casting provides a compact, protective enclosure for the mechanical and electrical components.

Heat-treated alloy steel gearing operates in an oil bath to provide the most reliable lubrication and effective heat dissipation.

WR-5 Series Hoists incorporate the following features:

- a. Overload limiting clutch.
- b. Completely independent mechanical and electrical brakes.
- c. Adjustable limit switches.
- d. Tough, nylon, weatherproof pushbutton stations.
- e. Steel strain cable inside pushbutton cord.
- f. Transformer isolated, low-voltage pushbutton controls.
- g. Quick voltage conversion on dual-voltage units.

1-4. Basic Hoist Data

The basic hoist models covered by this manual are listed in Table 1-1.

TABLE 1-1. BASIC HOIST DATA

Model Number	Rated Load (Lbs)	Lift Speed At Rated Load (Ft. Per Min.)	Motor HP
WR-6026	6,000	26	5
WR-10016	10,000	16	5

1-5. Application Information

This hoist is intended for general industrial use in the lifting and transporting of freely suspended material loads within its rated load. Prior to installation and operation, the user should review his application for abnormal environmental or handling conditions and to observe the applicable recommendations as follows:

- a. **Adverse Environmental Conditions.** Do not use the hoist in areas containing flammable vapors, liquids, gases or any combustible dusts or fibers. Refer to Article 500 of *The National Electric Code*. Do not use this hoist in highly corrosive, abrasive or wet environments. Do not use this hoist in applications involving extended exposure to ambient temperatures below - 10°F or above 130°F.
- b. **Lifting of Hazardous Loads.** This hoist is not recommended for use in lifting or transporting hazardous loads or materials which could cause widespread damage if dropped. The lifting of loads which could explode or create chemical or radioactive contamination if dropped requires fail-safe redundant supporting devices which are not incorporated into this hoist.
- c. **Lifting of Guided Loads.** This hoist is not recommended for use in the lifting of guided loads, including dumbwaiters and non-riding elevators. Such applications require additional protective devices which are not incorporated into this hoist. Refer to your state and local regulations governing the requirements for elevator and dumbwaiter installations.

1-6. Warranty

Every hoist is thoroughly inspected and tested prior to shipment from the factory. Should any problems develop, return the complete hoist prepaid to your nearest Duff-Norton Authorized Warranty Repair Station. If inspection reveals that the problem is caused by defective workmanship or material, repairs will be made without charge and the hoist will be returned, transportation prepaid.

This warranty does not apply where: (1) deterioration is caused by normal wear, abuse, improper or inadequate power supply, eccentric or side loading, overloading, chemical or abrasive actions, improper maintenance or excessive heat; (2) problems resulted from repairs, modifications or alterations made by persons other than factory or Duff-Norton Authorized Warranty Repair Station personnel; (3) the hoist has been abused or damaged as a result of an accident; (4) repair parts or accessories other than those supplied by Duff-Norton are used on the hoist. Equipment and accessories not of the seller's manufacture are warranted only to the extent that they are warranted by the manufacturer. EXCEPT AS STATED HEREIN, DUFF-NORTON MAKES NO OTHER WARRANTIES, EXPRESS OR IMPLIED, INCLUDING WARRANTIES OF MERCHANTABILITY AND FITNESS FOR A PARTICULAR PURPOSE.

SECTION II INSTALLATION

2-1. Safety Notes

- a. Inspect the hoist for any evidence of shipping damage or loose parts.
- b. The supporting structure and load attaching devices should have a load rating at least equal to that of the hoist.
- c. This hoist is not suitable for use in uncovered outdoor locations or areas containing explosive dust, vapors or gases.
- d. The installation area must provide safe operating conditions for the operator, including sufficient room for the operator and other personnel to stand clear of the load at all times.

2-2. Trolley Installation

Coffing® trolleys can be mounted on American Standard I Beams from 8 to 18 inches high. Adjustment for different beam dimensions is accomplished with the proper placement of spacer washers as described below.

- a. **"I"-Beam Adjustment.** Adjustment for "I" beam sizes and tolerances is accomplished by locating the spacer washers as shown in Figure 2-1. Table 2-1 provides an approximate guide to washer placement. Be sure to use the proper Table, based on lift and trolley-type of the particular installation.

BEAM MANUFACTURING TOLERANCES ALLOW WIDE VARIATIONS FROM HANDBOOK FLANGE WIDTHS, AND SLIGHT CHANGES TO RECOMMENDED WASHER DISTRIBUTION MAY BE NECESSARY TO SUIT SPECIFIC INSTALLATIONS.

The particular beam on which your hoist is to be installed should be measured and trolley spacer washers adjusted as required to achieve a clearance of 3/32" to 1/8".

Trolleys can be mounted on beam radii as small as 4 feet. Slightly increased spacing may be required when the trolley is mounted on curved beams to maintain freedom of movement.

The load pin nuts for the trolleys require a tightening torque of 140-160 ft. lbs. Refer to Figure 2-1 for nut identification.

- b. **Periodic Inspection.** The trolley should be inspected periodically for evidence of excess wear or overload. Parts should be replaced as required.
- c. **Lubrication.** Trolley wheels are equipped with sealed, lifetime lubricated, precision ball bearings which should not require lubrication for the normal service of the trolley.

2-3. Power Supply Connection

- a. Disconnect power before making connections.
- b. Voltage supplied to the hoist should be within plus or minus 10% of the voltage specified for the hoist. Hoists are tagged at the factory with a tag indicating the voltage for which the hoist is wired. Standard single-speed, three-phase hoists are convertible from 460 volts to 230 volts. See the Wiring section (paragraph 7-1) for voltage conversion instructions.
- c. National Electrical Code (ANSI C1) and local electrical codes should be consulted and proper disconnects, branch circuit protectors and wiring provided.
- d. Regardless of the method of electrification (power cord, festooning, cord reel or current collector), there must be a grounding conductor connected from the hoist to the electrical system ground.

- e. When installing a three-phase hoist, make only temporary connections at the power line. Push the "UP" button and observe the direction of the hook. If it raises, the phasing is correct and permanent connections may be made at the power line. If the load block lowers when the "UP" button is pushed, release the button immediately since the limit switches will not operate to protect the hoist from overtravel. Reverse the red and black wires at the power line connection to correct the hook direction.

CAUTION

Do not change connections in the hoist or the pushbutton assembly.

2-4. Vented Transmission

This hoist has an oil-bath, vented transmission. Keep the hoist reasonably level during shipment, storage and installation. This will avoid loss of transmission oil through the vent hole.

2-5. Wire Rope Lubrication

It is important that the wire rope is lubricated before the hoist is put into service. Wire rope lubricant is packed with each hoist. For lubrication instructions, see paragraph 5-5a. Additional lubricant is available from your Duff-Norton distributor. Specify Part No. 14J49.

2-6. Testing

- a. Before placing the hoist into operation, check for proper limit switch operation. Push the "UP" button and verify that the hook block stops at least 3 inches from the bottom of the hoist. Run the hoist down to its lower limit. At least 2 wraps of wire rope should remain on the drum. If either switch is not correct, adjust according to the procedure outlined in paragraph 5-2.

NOTE

- The upper and lower limit switches are factory set to provide the maximum allowable hook travel. **This travel adjustment should not be increased.** However, the switches may be adjusted to stop the hook sooner at either end of its travel.
- b. Wire rope life can be extended by a short breaking-in period before the hoist is put into service. During this breaking-in period, a small amount of twist may show up in the rope. This twist should be removed as described below. This break-in can be done at the time of hoist testing:
 1. Attach a light load to the hook and run the hoist through its full lift stroke for a few lifting and lowering cycles. Check for hook drift. The hook should not drift more than one inch.
 2. If brake operation is normal with a light load, repeat the above procedure with approximately one-half rated load, again running the hoist through its full lift stroke for a few cycles. Check again for hook drift.
 3. If brake operation is normal with one-half rated load, attach rated load to the hook and continue the break-in procedure. The hoist shall operate smoothly and the brake should prevent hook drift in excess of one inch at rated load. See paragraph 5-3 if motor brake adjustment is required.

4. Unload the hoist and position the bottom block so that it is freely suspended near the floor. If the block tends to twist about a vertical axis, this is evidence of twist in the wire rope. This twist should be removed as follows:
 - a. Push "DOWN" button and run rope out until stopped by lower limit switch. If necessary, move the unloaded block out from under the hoist to avoid looping and tangling the rope.
 - b. DISCONNECT POWER from the hoist and remove the control cover.
 - c. With a screwdriver, push the spring guide plate (1, Figure 5-1) out of the slots in the plastic limit switch nuts. Turn the green slotted nut (3) back to about the center of the threaded screw. DO NOT DISCONNECT THE WIRES FROM THE LIMIT SWITCHES.
 - d. With the control cover off, connect hoist to power supply. Be sure the green wire is grounded.
- e. Carefully jog the "DOWN" button until all the rope is run off and the drum socket openings are accessible.
- f. DISCONNECT POWER from the hoist.
- g. Slide each sleeve fitting out of its drum socket, and relieve any twist. If any twist is detected between the equalizer sheave and the bottom block, the twist must be passed through the block and relieved at the drum sleeve fitting end.
- h. Insert each sleeve fitting into the drum sockets, making sure the fittings are properly seated.
- i. Push the "UP" button until a few wraps of rope are wound onto the drum. Apply slight tension to the ropes with gloved hands to wind the rope evenly on the drum.
- j. Adjust the limit switches per paragraph 5-2.

TROLLEY I-BEAM ADJUSTMENT DATA

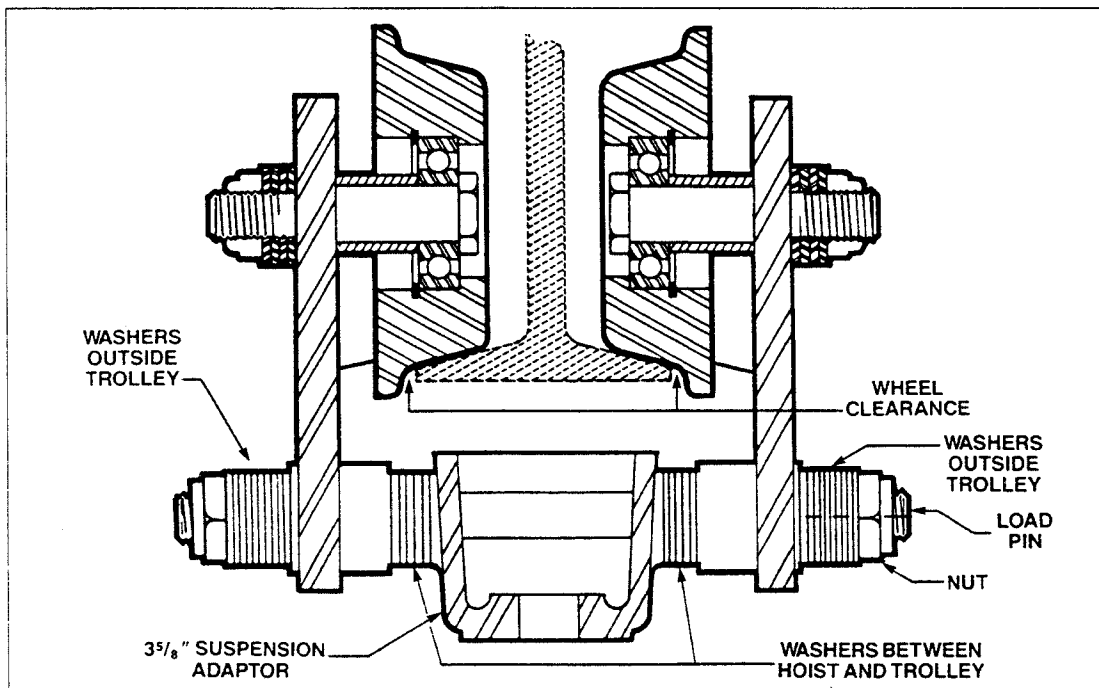

FIGURE 2-1

TABLE 2-1

I-Beam Size and Weight	Flange Width	Point A		Point B		Washer Stack Thickness Between Suspension Adapter And Sleeve
		Washers Between Suspension Adapter And Sleeve		Washers Between Sideplate and Nut		
		Thick (.135)	Thin (.075)	Thick (.135)	Thin (.075)	
S 8 x 18.4 #	4.000	3	0	4	9	.405
S 8 x 23.0 #	4.171	2	3	5	6	.495
S 10 x 25.4 #	4.660	1	8	6	1	.735
S 10 x 35.0 #	4.944	6	1	1	8	.885
S 12 x 31.8 #	5.000	4	5	3	4	.915
S 12 x 35.0 #	5.078	7	0	0	9	.945
S 15 x 42.9 #	5.500	7	3	0	6	1.170
S 15 x 50.0 #	5.640	7	4	0	5	1.245
S 18 x 54.7 #	6.000	6	8	1	1	1.410

*American Standard I-Beam

NOTE: All dimensions are in inches unless otherwise specified.

SECTION III OPERATION

3-1. General

This section presents information concerning the proper operation of the Coffing® Electric Wire Rope Hoist. It is not intended to serve as a handbook on rigging. Rigging, the process of moving heavy loads using mechanical devices, requires special knowledge and equipment. For information on the safe use of slings and similar rigging gear, users are urged to consult a textbook on rigging.

3-2. Safety Notes

- a. Inspect the hoist for any sign of loose, broken or malfunctioning parts (see Section IV). Any malfunctioning hoist should be tagged as “out of order” and removed from service until the defect is corrected.
- b. Before starting the hoist, the operator should be certain that all personnel are clear.
- c. Do not lift more than the rated load of the hoist.
- d. Do not lift people or loads over people.
- e. Avoid jogging controls or quick reversals of suspended loads.
- f. Do not leave a suspended load unattended.
- g. The operator should have a clear view of the load any time it is moving and should be sure that the load does not contact any obstructions.
- h. Read ANSI B30.16 Safety Standard for Overhead Hoists.

3-3 Handling The Load

- a. Align hoist directly over load. Avoid side pull, since this can cause the wire rope to jump grooves or overwrap itself. This condition will quickly damage the wire rope.

- b. The wire rope should not be wrapped around the load. Use proper slings.
- c. Be sure the wire rope is properly seated in the drum groove and in the bottom block sheave.
- d. Bring the hook into engagement with the load and make sure it is well seated before proceeding to lift the load. Be sure that the load is equalized on all supporting ropes.
- e. Lift the load just clear of its supports and stop the hoist to check for proper brake operation.
- f. Avoid letting the hook or load swing excessively while moving a trolley-suspended hoist.

3-4. Overload Limiting Protection

This hoist is equipped with a factory-calibrated overload limiting clutch, which will permit the lifting of loads within its load rating, but will prevent the lifting of damaging overloads while the hoist is being operated. If the load being lifted exceeds the lifting capability of the overload clutch, the hoist motor will continue to run, causing overheating of both the clutch and the motor. This condition should be avoided by immediately releasing the “UP” button and reducing the load to within the hoist load rating.

CAUTION

The overload limiting clutch is an emergency protective device and should not be used to measure the maximum load to be lifted, or to sense the overload imposed by a constrained load. Manufacturing tolerances require that the clutch be set somewhat above the load rating of the hoist. The fact that the hoist will pick up loads in excess of its load rating does not in any way sanction the use of the hoist in an overloaded condition.

SECTION IV INSPECTION

4-1. General

A scheduled inspection routine should be established for this hoist based upon severity of use and environmental conditions. Some inspections should be made frequently (daily to monthly) and others periodically (monthly to yearly). It is suggested that an Inspection and Maintenance Check List and an Inspector's Report similar to those shown in Figures 4-1 and 4-2 be used and filed for reference. All inspections should be made by a designated inspector. Special inspections should be made after any significant repairs or any situation causing suspicion that the hoist may have been damaged. Any hoist which has been removed from service for an extended time should receive an inspection as described under Periodic Inspections. ANSI B30.16, Safety Standard for Overhead Hoists, provides guidelines for hoist operation and inspection.

CAUTION

Any unsafe condition disclosed by any inspection must be corrected before operation of the hoist is resumed.

4-2. Frequent Inspection

- a. Check pushbutton station, brake and limit switches for proper operation.
- b. Check hooks for deformation, chemical damage or cracks. Bent hooks or hooks damaged from chemicals, deformation, cracks or having excessive throat opening (see paragraph 4-6) should be replaced. Visible deformation of any hook may be evidence of hoist abuse and overloading and indicates that a thorough inspection of the complete hoist should be made.
- c. Check that bottom hook swivels freely.
- d. Check for missing, bent or otherwise damaged hook latches.
- e. Check pushbutton and power cord for cuts or other damage.
- f. Check wire rope for wear, twist, distortion or kinks.

4-3. Periodic Inspection

The exact period for the following inspections will depend on the anticipated severity of hoist use. Determination of this period should be based on the user's experience. It is recommended that the user begin with a monthly inspection and extend the periods to quarterly, semiannually or annually, based on his monthly inspection experience.

- a. Clean hoist of any dirt or foreign material. Inspect bottom block for accumulation of debris.
- b. Perform all frequent inspections listed above.
- c. Check for loose bolts, screws and nuts.
- d. Check housings load block and other parts for wear, corrosion, cracks or distortion. Check for abnormal openings between housing sections.
- e. Check motor brake for worn discs, oil contamination or excessive clearance (see paragraph 5-2).
- f. Check mechanical load brake function (see paragraph 4-4).
- g. Inspect the entire length of wire rope for deficiencies. See WIRE ROPE INSPECTION, paragraph 4-5.
- h. Inspect hooks and suspension parts for cracks, distortion or extreme wear.
 - i. Inspect hooks for cracks using magnetic particle, dye penetrant or other crack-detecting methods.
 - j. Check limit switch set points and reset if necessary (see paragraph 5-1).
 - k. Inspect all wiring for defective insulation, and check to be sure all electrical connections are tight. Check motor reversing contactor or relay for burned contacts.
 - l. Inspect for oil leaks. Check oil level.
 - m. Inspect for missing or illegible capacity or warning labels.
 - n. Inspect the supporting structure for continued ability to support the hoist rated load.

**INSPECTION AND MAINTENANCE CHECK LIST
ELECTRIC-POWERED OVERHEAD WIRE ROPE HOIST**

TYPE OF HOIST _____ CAPACITY (TONS) _____
 LOCATION _____ ORIGINAL INSTALLATION DATE _____
 MANUFACTURER _____ MANUFACTURER'S SERIAL NO. _____

ITEM	FREQUENCY OF INSPECTION			POSSIBLE DEFICIENCIES	OK	ACTION REQUIRED
	FREQUENT		PERIODIC			
	DAILY	MONTHLY	1-12 MO.			
Operating Controls	•	•	•	Any deficiency causing improper operation		
Limit Switches	•	•	•	Any deficiency causing improper operation Pitting or deterioration		
Disc (Motor) Brake	•	•	•	Slippage or excessive wear Glazing, contamination or excessive wear		
Load Brake (Mechanical)			•	Failure to support load with disc brake open (see paragraph 4-4)		
Hooks	•	•	•	Excessive throat opening, bent or twisted more than 10 degrees, damaged hook latch, wear, chemical damage, worn hook bearing Cracks (use dye penetrant, magnetic particle or other suitable detection method)		
Suspension Lug			•	Cracks, excessive wear or other damage which may impair the strength of the lug Cracks (use dye penetrant, magnetic particle or other suitable detection method)		
Wire Rope	•	•	•	Inadequate lubrication, wear, twist, distortion, improper dead-ending, deposits of foreign substance Deterioration or wear resulting in appreciable loss of original strength		
Suspension Lug Connections			•	Cracks, bending, stripped threads, damaged kingbolts		
Pins, Bearings, Bushings, Shafts Couplings, Gears			•	Excessive wear, corrosion, cracks, distortion		
Nuts, Bolts, Rivets			•	Looseness, stripped and damaged threads, corrosion		
Sheave, Drum			•	Distortion, cracks and excessive wear Build-up of foreign substances		
Housings, Load Block			•	Cracks, distortion, excessive wear Internal build-up of foreign substances.		
Wiring and Terminals			•	Fraying, defective insulation		
Contact Block, Magnetic Hoist Control Switch, Other Electrical Apparatus			•	Loose connections, burned or pitted contacts		
Supporting Structure and Trolley (if used)			•	Damage or wear which restricts ability to support imposed loads		
Nameplates, Decals Warning Labels			•	Missing, damaged or illegible		
Transmission Lubricant			•	Low Level, Requires Changing		

NOTE: Refer to Maintenance and Inspection Sections of the Hoist Maintenance Manual for further details.

FREQUENCY OF INSPECTION:

Frequent - Indicates items requiring inspection daily to monthly. Daily inspections may be performed by the operator if properly designated.

Periodic - Indicates items requiring inspection monthly to yearly. Inspections to be performed by or under the direction of a properly designated person. The exact period of inspection will depend on frequency and type of usage. Determination of this period will be based on the user's experience. It is recommended that the user begin with a monthly inspection and extend the periods to quarterly, semiannually or annually based on his monthly experience.

FIGURE 4-1. RECOMMENDED INSPECTION AND MAINTENANCE CHECK LIST

INSPECTOR'S REPORT			
ITEM	REMARKS (LIST DEFICIENCIES AND RECOMMENDED ACTION)		
INSPECTOR'S SIGNATURE	DATE INSPECTED	APPROVED BY	DATE

FIGURE 4-2. RECOMMENDED INSPECTOR'S REPORT.

4-4. Load Brake Function Check

To check the functioning of the mechanical load brake, proceed as follows:

- a. Attach a light load to the hoist and lift it several inches.
- b. DISCONNECT HOIST FROM POWER SUPPLY and remove control cover (see Figure 8-7, Index No. 15).
- c. Referring to Figure 4-3 and Figure 8-6, place screwdrivers behind the plate and armature assembly and prepare to pry against the transmission housing.

NOTE

Do not allow either screwdriver to contact brake disc (see Figure 8-6, Index No. 7).

- d. Carefully pry open motor brake (close solenoid gap) and observe action of load. The load may descend a short distance at first, until the pawls engage the ratchet in the internal load brake. After that, if the load descends, the mechanical load brake is malfunctioning and should be repaired.

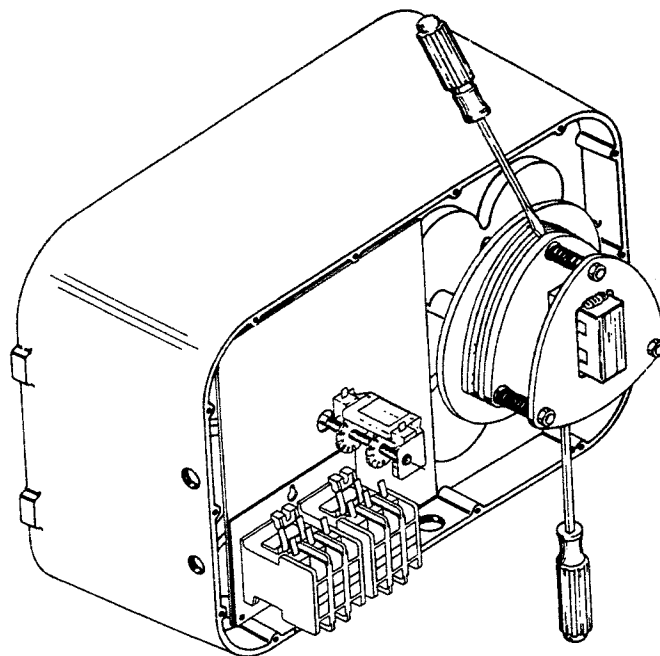

FIGURE 4-3. LOAD BRAKE FUNCTION CHECK

4-5. Wire Rope Inspection

- a. Make a thorough inspection of the wire rope at least once each month and keep a written, dated and signed report of rope condition on file. Any deterioration, resulting in appreciable loss of original strength, such as described below, shall be carefully noted and determination made as to whether further use of the rope would constitute a safety hazard. See Figure 4-4 for identification of wire rope components.
- 1) Reduction of rope diameter below nominal due to loss of core support, internal or external corrosion or wear of outside wires.
 - 2) A number of broken outside wires and the degree or distribution or concentration of such broken wires.
 - 3) Worn outside wires.
 - 4) Sections of rope which are normally hidden during inspection or maintenance procedures, such as parts passing over sheaves, should be given close inspection as these are points most subject to deterioration.
 - 5) Corroded or broken wires at end connections.
 - 6) Corroded, cracked, bent, worn or improperly applied end connections.
 - 7) Kinking, crushing, cutting or unstranding.
- b. No precise rules can be given for determination of exact time for replacement of wire rope, since many variable factors are involved. Safety in this respect depends largely upon the used of good judgment in evaluating remaining strength in the use rope after allowance for deterioration disclosed by

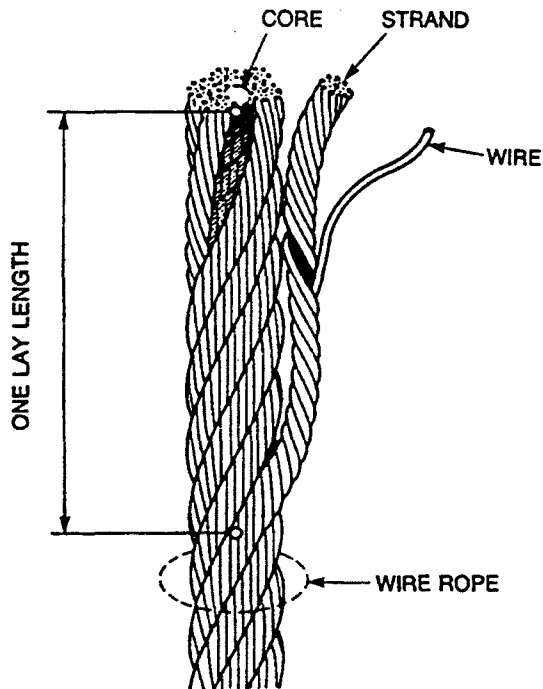

FIGURE 4-4. BASIC COMPONENTS OF WIRE ROPE

inspection. Safety of rope operation depends upon this remaining strength. Conditions such as the following should be sufficient reason for questioning rope safety and consideration of replacement.

- 1) Twelve randomly distributed broken wires in one rope lay length or four broken wires in one strand in one rope lay length. One lay is the length, parallel to the longitudinal axis, in which a strand makes one complete turn about the axis of the rope. See Figure 4-4.
- 2) Two wires broken adjacent at the end fittings.
- 3) Wear of one-third of the original diameter of outside individual wires.
- 4) Kinking, crushing, birdcaging or any other damage resulting in distortion of the rope structure.
- 5) Evidence of any heat damage from any cause.
- 6) Reductions from nominal 3/8-inch diameter to 23/64 inch.

CAUTION

Use only wire rope assemblies supplied by our company since replacement rope assemblies must be of the same size, grade and construction rope and have the same swaged end fittings as the original rope assembly.

4-6. Hook Throat Opening

Check throat opening as indicated in Figure 4-5. Replace hook if measurement exceeds the allowable.

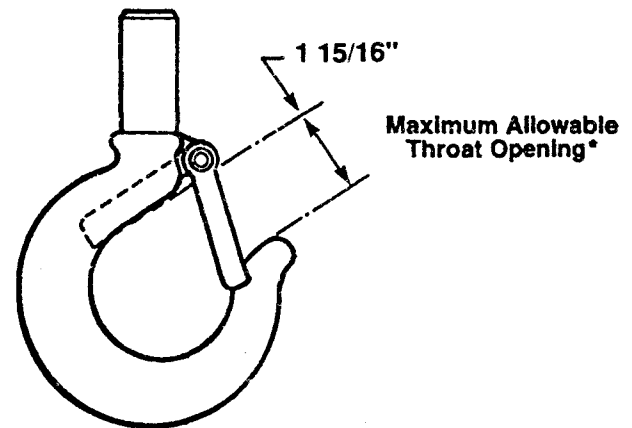

*Dimension of throat opening with internal latch. Note: Add 1/16" if measured without hook latch.

FIGURE 4-5. HOOK THROAT OPENING

SECTION V MAINTENANCE AND REPAIR

5-1. General

This section provides instructions for the most common routine maintenance and adjustments. Major repairs are not within the scope of this manual and should be referred to qualified service facilities.

SAFETY NOTE

Always remove load and disconnect hoist from power supply before removing end covers or making repairs.

5-2. Limit Switch Adjustment

Limit switches are provided to protect the hoist against damage resulting from overtravel. For easy identification the upper (No. 2, Figure 5-1) and lower (No. 3, Figure 5-1) limit switch adjusting nuts are colored red and green respectively. Each limit switch nut has ten slots for adjustment, and the increment of adjustment is such that one slot is equivalent to approximately 1 1/8" of hook travel. Care should be exercised when adjusting either limit of travel.

a. Adjusting Upper Limit (Red Nut)

- 1) Carefully raise the load block to a point where its top is 3" or more from the hoist housing.
- 2) DISCONNECT POWER from the hoist and remove the control cover.
- 3) With a screwdriver, pry the spring guide plate (No. 1, Figure 5-1) out of the slots in the colored limit switch nuts (Nos. 2 and 3).

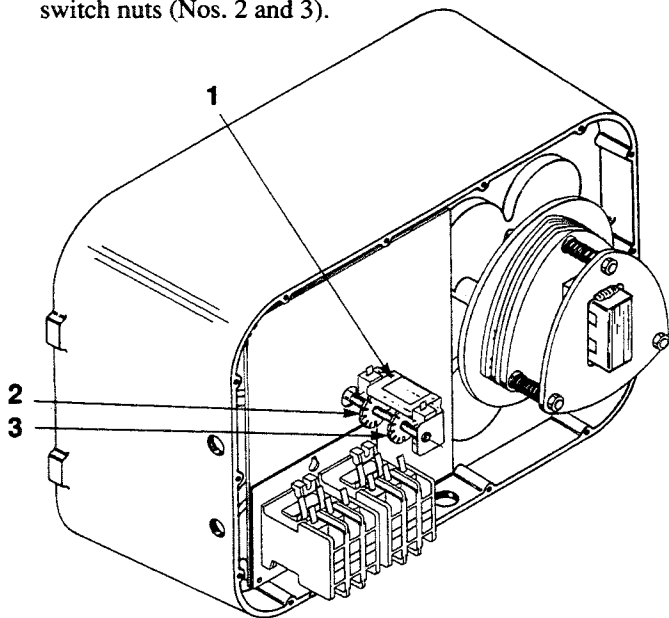

FIGURE 5-1. LIMIT SWITCH ADJUSTMENT

- 4) Turn the slotted red nut (No. 2) toward its limit switch until the switch clicks.
- 5) Release the spring guide plate and be sure it snaps back into the slots in both nuts. Do not disturb the other slotted nut if it has been previously set.
- 6) Replace the control cover and reconnect power to the hoist.
- 7) Carefully raise the load block to its upper limit and observe to see if it stops automatically at the desired point. Do not allow the load block to run into the hoist drum. The stopping point should be at least 3" below the hoist drum.

b. Adjusting Lower Limit (Green Nut)

- 1) Carefully lower the load block to a point where at least 2 wraps of wire rope remain on each end of the drum.
- 2) DISCONNECT POWER from the hoist and remove the control cover.
- 3) Adjust the green limit switch nut in the same manner described above for the red nut.
- 4) Replace the control cover and reconnect power to the hoist.
- 5) Carefully lower the load block to its lower limit and observe if it stops automatically at the desired level. At least 2 wraps of wire rope should remain on each end of the drum.

NOTE

If upper and lower limits are not operating satisfactorily, repeat adjustment.

5-3. Motor Brake Adjustment

When properly adjusted, the multiple disc motor brake should release promptly, operate without noticeable chatter, and stop the load with no more than one inch of drift. If the hoist hesitates to lift the load promptly when the pushbutton is depressed, the brake should be adjusted per the following procedure.

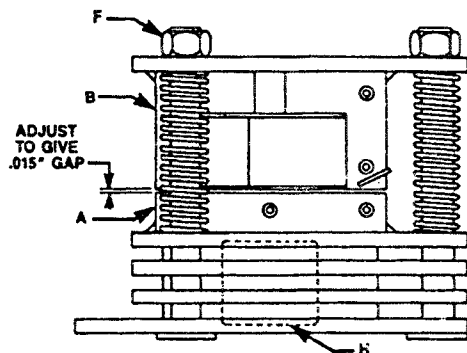

FIGURE 5.2. MOTOR BRAKE ADJUSTMENT

- a. Remove any load and DISCONNECT POWER from hoist.
- b. Remove the control cover.
- c. Referring to Figure 5-2, check the gap between armature (A) and frame (B). The correct gap is .015".
- d. Adjust the gap by turning the three lock nuts (F) and check with a feeler gauge to be sure the gap is the same on both ends of the solenoid.

CAUTION

Be sure the bottom of the armature does not touch the splined adapter (H). As wear occurs, the original clearance will be reduced. When this clearance is gone, THE BRAKE DISCS MUST BE REPLACED.

- e. Replace control cover and reconnect power. If the brake still chatters or is hesitant to release, refer to Section VI, Troubleshooting.

5-4. Wire Rope Replacement

Refer to Figure 5-3 for parts identification and proper reeving.

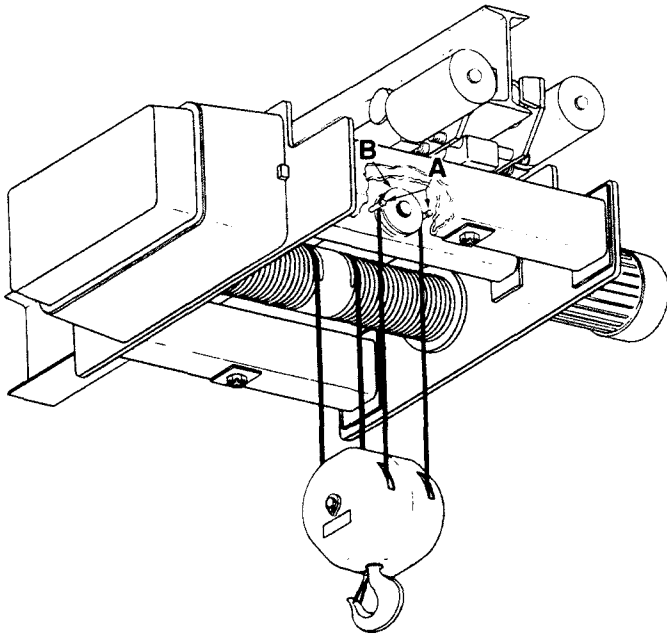

FIGURE 5-3. TWO PART DOUBLE REEVING

- a. Push “DOWN” button and run old rope out until stopped by lower limit switch.
- b. Disassemble the load block by removing the hex socket locking screws (14, Figure 8-3) and the hex head screws (12, Figure 8-3). The block covers (11, Figure 8-3) will still be captured by the rope. Clean and inspect the hook, sheaves, bearings and yoke for wear, damage, etc. Replace parts as necessary. Do not reassemble the load block yet.
- c. **DISCONNECT POWER** from the hoist and remove the control cover.
- d. With a screwdriver, push the spring guide plate (1, Figure 5-1) out of the slots in the plastic limit switch nuts. Turn the green slotted nut (3) back to about the center of the threaded screw. **DO NOT DISCONNECT THE WIRES FROM THE LIMIT SWITCHES.**
- e. With the control cover off, connect hoist to power supply. Be sure the green wire is grounded.
- f. Carefully jog the “DOWN” button until all the old rope is run off and the drum socket openings are accessible.
- g. **DISCONNECT POWER** from the hoist.
- h. Remove the two rope guards (A, Figure 5-3) and lift the rope off the equalizer sheave (B).
- i. Slide the sleeve fittings out of the drum sockets and out of the block covers. Remove and discard the old rope.

- j. Place paper on floor to protect the new wire rope from dirt and grit. Stretch the new rope out in one length and relieve any twist. Then double the rope by bringing the two sleeve fittings together.
- k. Pass each sleeve fitting through the rope openings in the block covers only. The block should remain disassembled at this point.
- l. Insert each sleeve fitting into the drum sockets, making sure the fittings are properly seated.
- m. Push the “UP” button until a few wraps of rope are wound onto the drum. Apply slight tension to the ropes with gloved hands to wind the rope evenly on the drum.
- n. Place the looped end over the equalizer sheave. Reinstall and tighten the rope guards.
- o. At this point, only the block covers will be hanging from the two loops of rope.

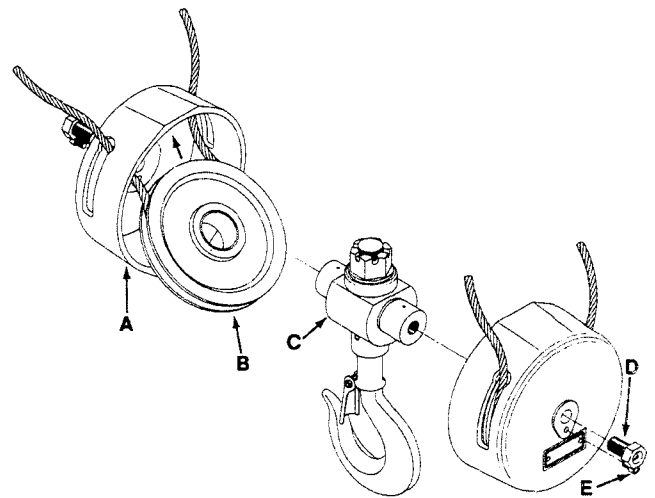

FIGURE 5-4. ASSEMBLY OF LOAD BLOCK

- p. Refer to Figure 5-4 for assembly of load block. Pull a loop of rope to the inside of the block cover (A), and place a sheave (B) in this loop. Angle the top of the sheave into the cover, while keeping the rope seated in the sheave groove. The sheave will now drop to the inside wall of the cover. Place the sheave and cover, as one unit, over the yoke (C), and hand-tighten the hex head screw (D). Repeat for the other side. Fully tighten both hex head screws (D), then back off until the hex socket locking screws (E) can be installed and tightened. Refer to Figure 5-3 to make sure that the rope is reeved correctly.
- q. Adjust the limit switches per paragraph 5-2.
- r. Lubricate the wire rope per paragraph 5-5a. Test the hoist and break-in the wire rope per paragraph 2-6b.

5-5. Lubrication

Proper lubrication is necessary for long, trouble-free hoist operation. Refer to the following and to Table 5-1, Recommended Lubrication Schedule, for lubrication points, type of lubricant and frequency of lubrication.

- a. **Wire Rope:** Lubrication of the wire rope is important. The action within the rope as it moves over the drum or around the sheave is for the strands to slide one against the other. Lubrication will reduce this friction and prevent the entrance of moisture which can cause corrosion. Frequent light applications of lubricant are better than infrequent heavy applications. For best results, use Coffing Wire Rope Lubricant (Part No. 14J49) or other wire rope lubricant. As an alternative, use SAE 30 motor oil.
- b. **Gearing:** The gear case of the hoist is filled at assembly with 2 gallons of a gear oil containing special friction-reducing additives.

WARNING

The use of gear oils other than that recommended in Table 5-1 can cause brake chatter or can render the load brake incapable of holding a load. A 1 gallon container of this oil is available from the Duff-Norton Co. (Part No. 14J11).

- a. **To check the oil level,** remove the pipe plug from the side of the hoist. With the hoist hanging level, transmission oil should be even with the edge of the tapped plug hole.

- b. The length of time between necessary oil changes will depend on the severity of use the hoist receives. In general, the oil should be changed every 12 months of normal operation, or every 200 hours of actual hoist on-time. Very heavy use or operation in high ambient temperatures (over 105°F) will require that oil be changed more often. An indication of the need for oil replacement is load brake noise. If an erratic tapping sound is made when lowering a load, the oil should be changed.
- c. **Limit Switch Shaft:** To prevent rust, the threaded limit switch shaft should be given a light coat of grease or sprayed with a general purpose lubricant.
- d. **Hook Bearing:** Apply a few drops of SAE 30 oil around the edge of the bearing.
- e. **Sheave Bearings:** At periodic inspection (see Figure 4-1), and when the wire rope is replaced, pump fresh grease into both grease fittings on the bottom block.
- f. **Drum Bearing:** At periodic inspection (see Figure 4-1), pump fresh grease into the grease fitting in the bearing cap (31, Figure 8-2).
- g. **Trolley Gear Box:** At periodic inspections (see Figure 4-1) check grease level by removing end cap (22, Figure 8-10). The gear box should be approximately half full of grease. In general, the trolley gear box lubricant does not require changing.
- h. **Trolley Wheel Gears:** Apply a light coat of grease to the pinion and both gears.

**TABLE 5-1. RECOMMENDED LUBRICATION SCHEDULE*
WR-5 SERIES ELECTRIC WIRE ROPE HOIST**

Figure And Index No.	Component	Type of Lubricant	Type of Service And Frequency of Lubrication		
			Heavy	Normal	Infrequent
Figure 8-2, No. 26	Wire Rope	Coffing Wire Rope Lubricant (Kit No. 14J49 contains 8 fl. oz.) or SAE 30 Gear or Motor Oil	Daily	Weekly	Monthly
Figure 8-4	Hoist Gearing	Two gallons of Coffing No. H-7813 transmission oil (Kit No. 14J11 contains one gallon of oil)	At periodic inspection (see Figure 4-1, paragraph 5-5b)		
Figure 8-7, No. 9	Limit Switch Shaft	"WD-40" or general purpose spray lubricant	Monthly	Yearly	Yearly
Figure 8-3, No. 5	Load Hook Bearing	SAE 30 Gear or Motor Oil	Weekly	Monthly	Yearly
Figure 8-3, No. 5	Sheave Bearings	NLGI #2 multipurpose lithium base grease (Coffing No. H-7610)	At periodic inspection (see Figure 4-1) Pump grease into grease fittings		
Figure 8-2, No. 28	Drum Bearing	NLGI #2 multipurpose lithium base grease (Coffing No. H-7610)	At periodic inspection (see Figure 4-1) Pump grease into grease fitting		
Figure 8-10	Trolley Gear Box	NLGI #2EP lithium base grease (Coffing No. H-7610)	At periodic inspection (see Figure 4-1)		
Figure 8-9, No. 18	Trolley Wheel Gears	NLGI #2 multipurpose lithium base grease (Coffing No. H-7610)	Weekly	Monthly	Yearly

NOTE: All bearings except hook and sheave bearings are prelubricated and sealed.

*This lubrication schedule is based on a hoist operating in normal environmental conditions. Hoists operating in adverse atmospheres containing excessive heat, corrosive fumes or vapors, abrasive dust, etc., should be lubricated more frequently.

SECTION VI TROUBLESHOOTING

6-1. General

Use the following table as an aid to troubleshoot your hoist. If you do not have an experienced machinist-electrician to do

your repair work, we recommend that you send your hoist to an approved service center for repairs.

TROUBLE

REMEDY

Hook Fails To Stop At End Of Travel.

<ol style="list-style-type: none"> 1. Limit switches not operating. 2. Plastic limit switch nuts not moving on shaft. 3. Magnetic reversing switch malfunction. 	<ol style="list-style-type: none"> 1. Check adjustment. See paragraph 5-2. Check connections against wiring diagram. Tighten loose connections or replace. 2. Check for stripped threads or bent nut guide. 3. Remove electrical cover and check reversing switch.
--	---

Hoist Does Not Respond To Pushbutton.

<ol style="list-style-type: none"> 1. Power failure in supply lines. 2. Wrong voltage or frequency. 3. Improper connections in hoist or pushbutton station. 4. Motor brake does not release. 5. Faulty magnetic hoist control switch. 	<ol style="list-style-type: none"> 1. Check circuit breakers, switches and connections in power supply lines. 2. Check voltage and frequency of power supply against the rating on the nameplate of the hoist. 3. Check all connections at line connectors and on terminal block. Check terminal block on dual-voltage hoists for proper voltage connections. 4. Check connections to the solenoid coil. Check for open or short circuit. Check for proper adjustment. See paragraph 5-3. 5. Check coils for open or short circuit. Check all connections in control circuit. Check for burned contacts. Replace as needed.
--	--

Hook Does Not Stop Promptly.

<ol style="list-style-type: none"> 1. Hoist overloaded. 2. Brake not holding. 	<ol style="list-style-type: none"> 1. Reduce load to within rated capacity of hoist. 2. Check motor brake adjustment (see paragraph 5-3, and load brake (paragraph 4-4).
---	--

Hook Moves In Wrong Direction.

<ol style="list-style-type: none"> 1. Three-phase reversal. 2. Improper connections. 	<ol style="list-style-type: none"> 1. Reverse any two wires (except the green ground wire) at the power source (see paragraph 2-3). 2. Check all connections against Wiring Diagram.
--	--

Hoist Hesitates To Lift When Energized.

<ol style="list-style-type: none"> 1. Hoist overloaded. 2. Motor brake requires adjustment. 3. Worn overload limiting clutches. 4. Low voltage. 	<ol style="list-style-type: none"> 1. Reduce load within rated capacity of hoist. 2. Check motor brake adjustment, see paragraph 5-3. 3. Replace clutches. 4. Check voltage at hoist power cord with hoist starting. Voltage should be no less than 90% of voltage specified on hoist.
---	--

Hook Raises But Will Not Lower. (Motor not running)

<ol style="list-style-type: none"> 1. "DOWN" circuit open. 2. Broken conductor in pushbutton cable. 3. Faulty magnetic hoist control switch. 	<ol style="list-style-type: none"> 1. Check circuit for loose connections. Check "DOWN" limit switch for malfunction. 2. Check each conductor in the cable. If one is broken, replace entire cable. 3. Check coils for open or short circuit. Check all connections in control circuit. Check for burned contacts. Replace as needed.
---	--

TROUBLE**REMEDY****Hook Raises But Will Not Lower When Motor Is Operating.**

Consult Factory Or Authorized Duff-Norton Warranty Repair Station.
--

Hook Lowers But Will Not Raise.

<ol style="list-style-type: none"> 1. Hoist overloaded. 2. Low voltage. 3. "UP" circuit open. 4. Broken conductor in pushbutton cable. 5. Faulty magnetic hoist control switch. 6. Worn overload limiting clutches. 	<ol style="list-style-type: none"> 1. Reduce load to within rated capacity. 2. Determine cause of low voltage and bring up to at least 90% of the voltage specified on hoist. Line voltage should be measured while holding or lifting load. 3. Check circuit for loose connections. Check "UP" limit switch for malfunction. 4. Check each conductor in the cable. If one is broken, replace entire cable. 5. Check coils for open or short circuit. Check all connections in control circuit. Check for burned contacts. Replace as needed. 6. Replace clutches.
---	--

Lack Of Proper Lifting Speed.

<ol style="list-style-type: none"> 1. Hoist overloaded. 2. Motor brake is dragging. 3. Low voltage. 4. Overload limiting clutches intermittently slipping. 	<ol style="list-style-type: none"> 1. Reduce load to within rated capacity of hoist. 2. Check for proper brake adjustment or other defects. See paragraph 5-3. 3. Bring up voltage to plus or minus 10% of voltage specified on hoist. Line voltage should be measured while hoist is lifting load. 4. Replace clutches.
--	--

Load Brake "Noise." (Erratic tapping sounds or squeals)

<ol style="list-style-type: none"> 1. Need transmission oil change or improper lubricant has been used. 2. Load brake malfunctioning. 	<ol style="list-style-type: none"> 1. Change transmission oil. See Table. 5-1. Note: Hoist Warranty is void if unapproved oil is used. 2. Check load brake operation. See paragraph 4-4.
---	--

Motor Brake Noise Or Chatter. (While starting hoist)

<ol style="list-style-type: none"> 1. Brake needs adjustment. 2. Low voltage. 	<ol style="list-style-type: none"> 1. Adjust as per paragraph 5-3. 2. Check voltage at hoist power cord with hoist starting. Voltage should be no less than 90% of the voltage specified.
---	---

Motor Brake "Buzz." (Any time hoist is running)

<ol style="list-style-type: none"> 1. Brake needs adjustment. 2. Broken shading coil on brake frame. 	<ol style="list-style-type: none"> 1. Adjust as per paragraph 5-3. 2. Replace shading coil or complete brake frame assembly.
--	--

SECTION VII WIRING

Safety Note

Disconnect power from hoist before removing end cover.

7-1. Voltage Conversion

Standard single speed three phase units are convertible from 460 to 230 volts. Conversion to the alternate voltage can be accomplished with the following procedure.

- a. Be sure power is disconnected from hoist.
- b. Transfer the following leads per the connection table on the appropriate wiring diagram. Transfer hoist motor leads T4, T5, T6, T7, T8 and T9 inside the hoist motor terminal box. Transfer transformer leads H2 and H3 under hoist end cover. If applicable, transfer trolley motor leads T4, T5, T6, T7, T8

and T9 under the splice plate at the trolley motor connection box.

- c. After converting voltage, check for proper phasing (see paragraph 2-3e) and check for proper limit switch operation.

NOTE

Units with either a two-speed hoist and/or a two-speed trolley are not voltage-convertible.

7-2. Wiring Diagrams

The wiring diagrams for standard hoist models are reproduced on the following pages. In addition, every hoist should have a wiring diagram located inside the end cover.

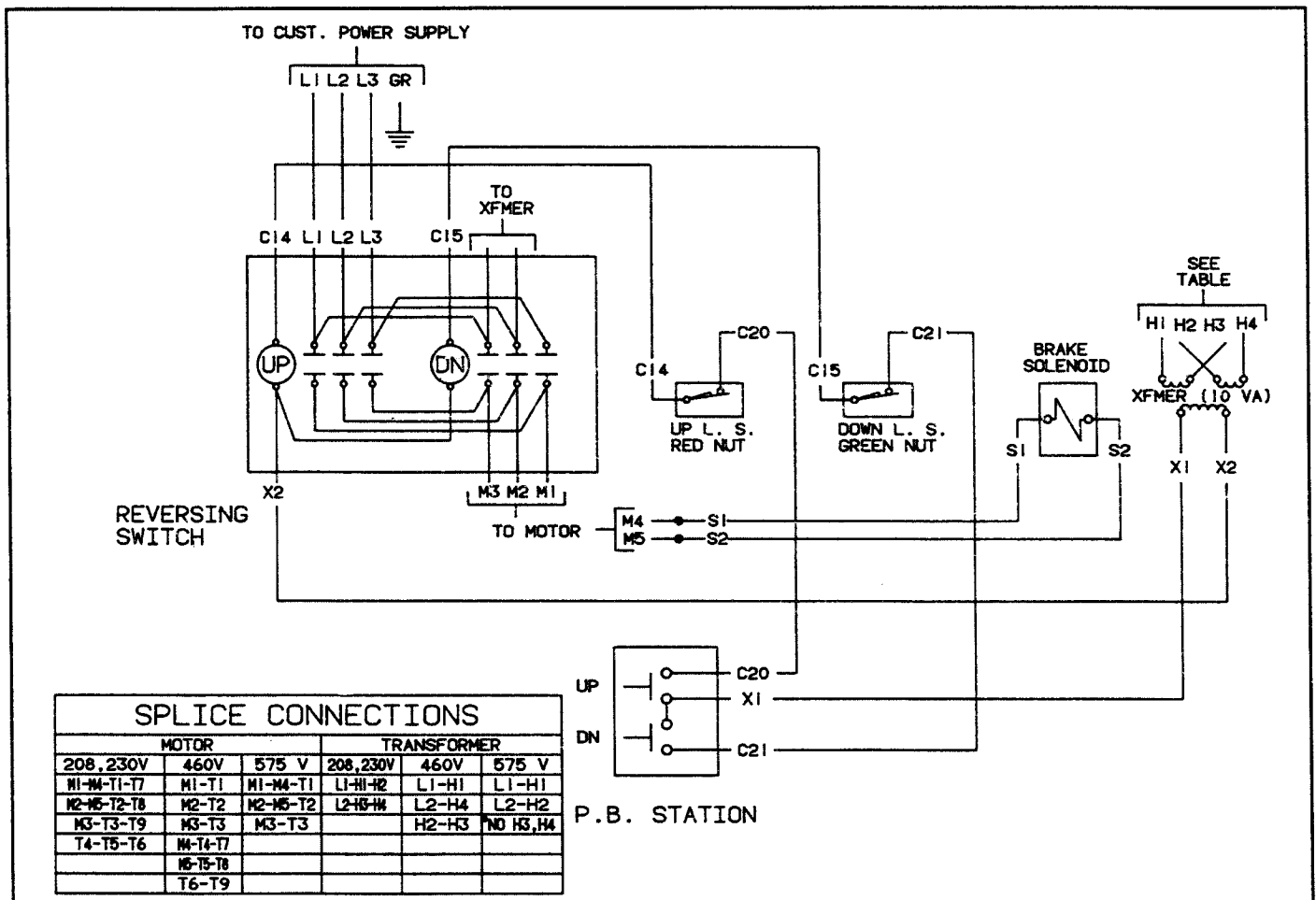

**FIGURE 7-1. WIRING DIAGRAM
208, 230/460, and 575V, 3 Phase, Single Speed Hoist
985 WR 1**

**FIGURE 7-2. WIRING DIAGRAM
230, 460, 575 and 208V, 3 Phase
Two Speed Hoist
985 WR 2**

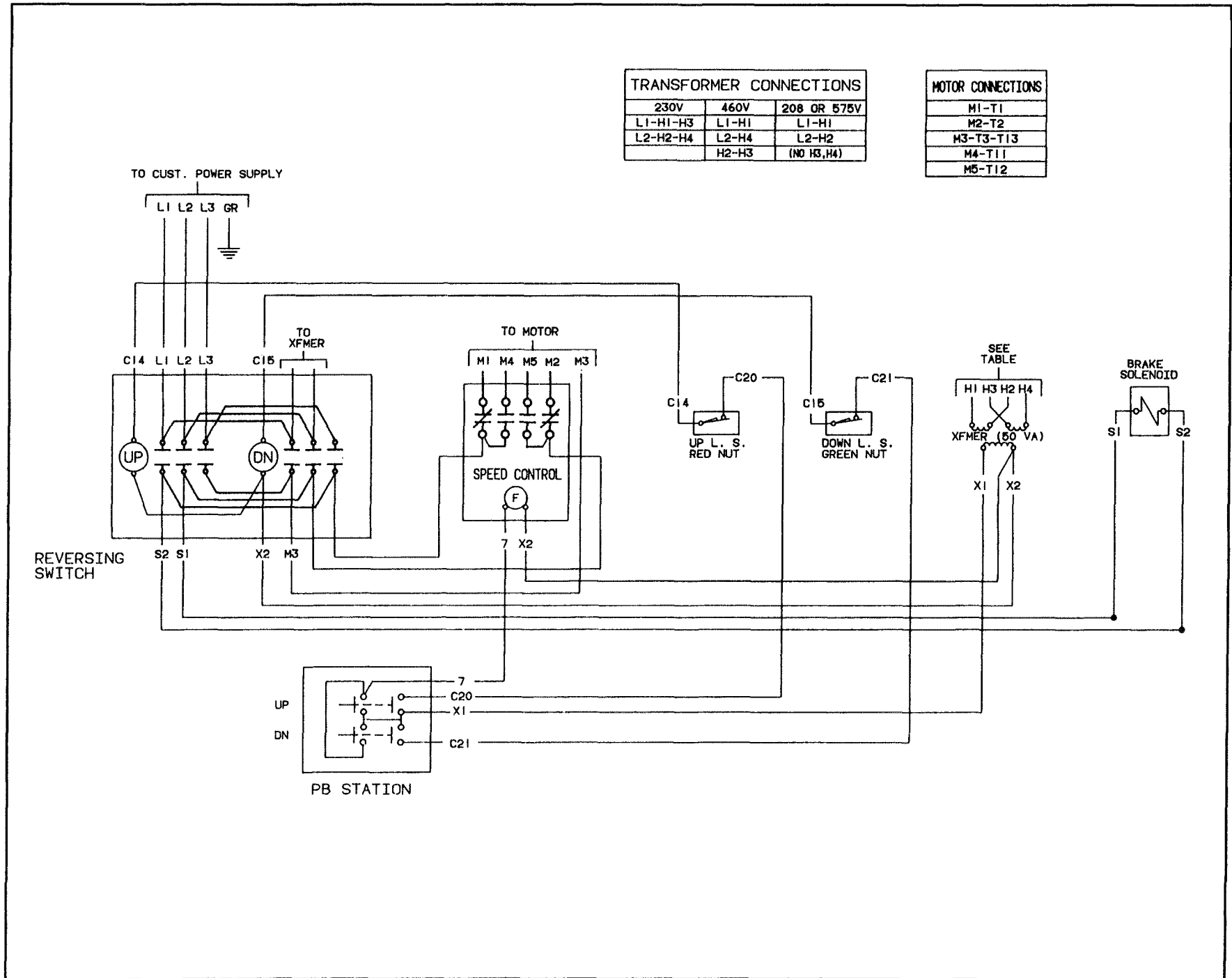

SPLICE CONNECTIONS			
	208, 230V	460V	575 V
HOIST MOTOR	M1-M4-T1-T7	M1-T1	M1-M4-T1
	M2-M5-T2-T8	M2-T2	M2-M5-T2
	M3-T3-T9	M3-T3	M3-T3
	T4-T5-T6	M4-T4-T7	
		M5-T5-T8	
TROLLEY MOTOR	C4-T1-T7	C4-T1	C4-T1
	C5-T2-T8	C5-T2	C5-T2
	C6-T3-T9	C6-T3	C6-T3
	T4-T5-T6	T4-T7	
		T5-T8	
XFMER	L1-H1-H2	L1-H1	L1-H1
	L2-H3-H4	L2-H4	L2-H2
		H2-H3	NO H3, H4

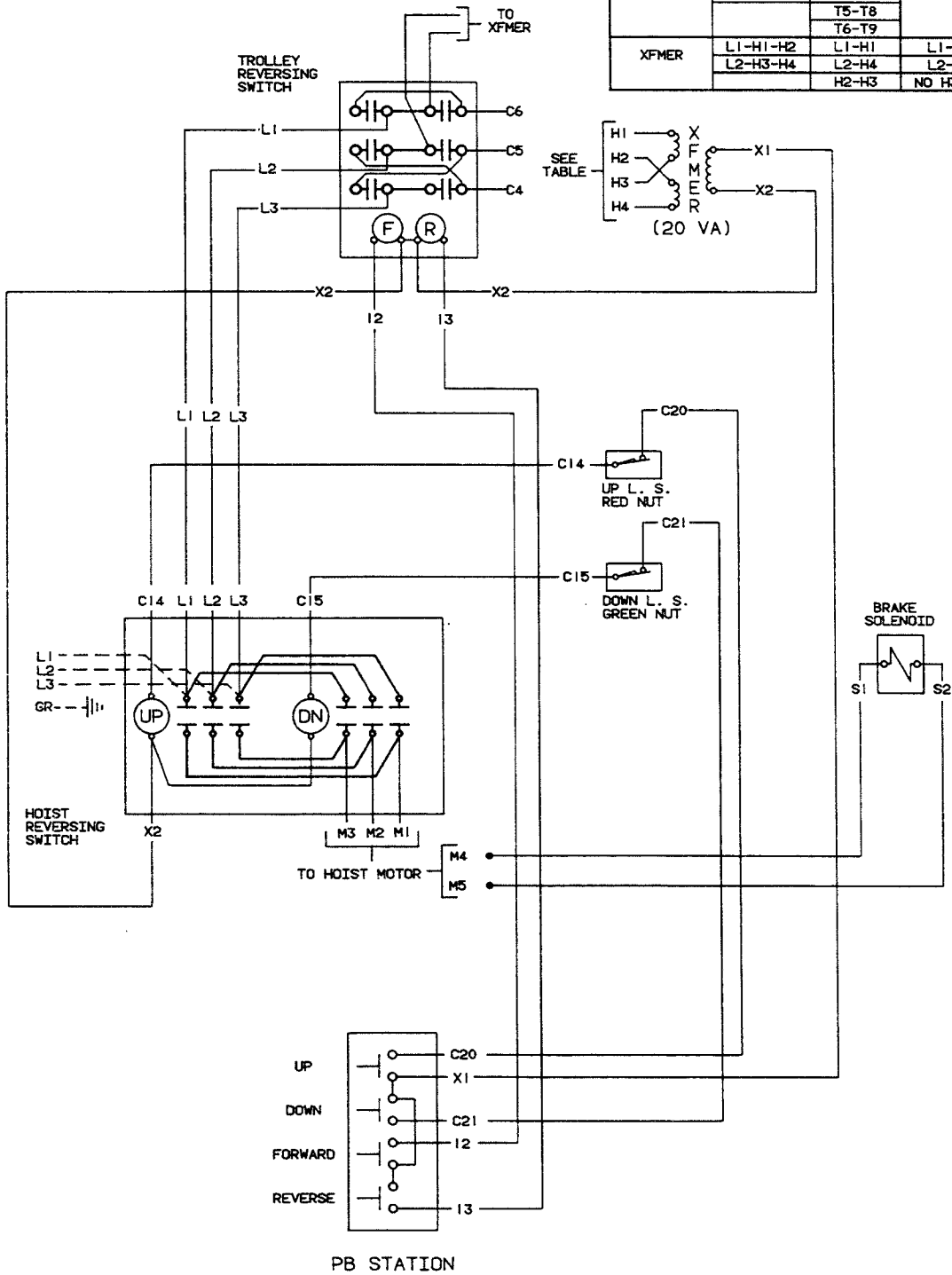
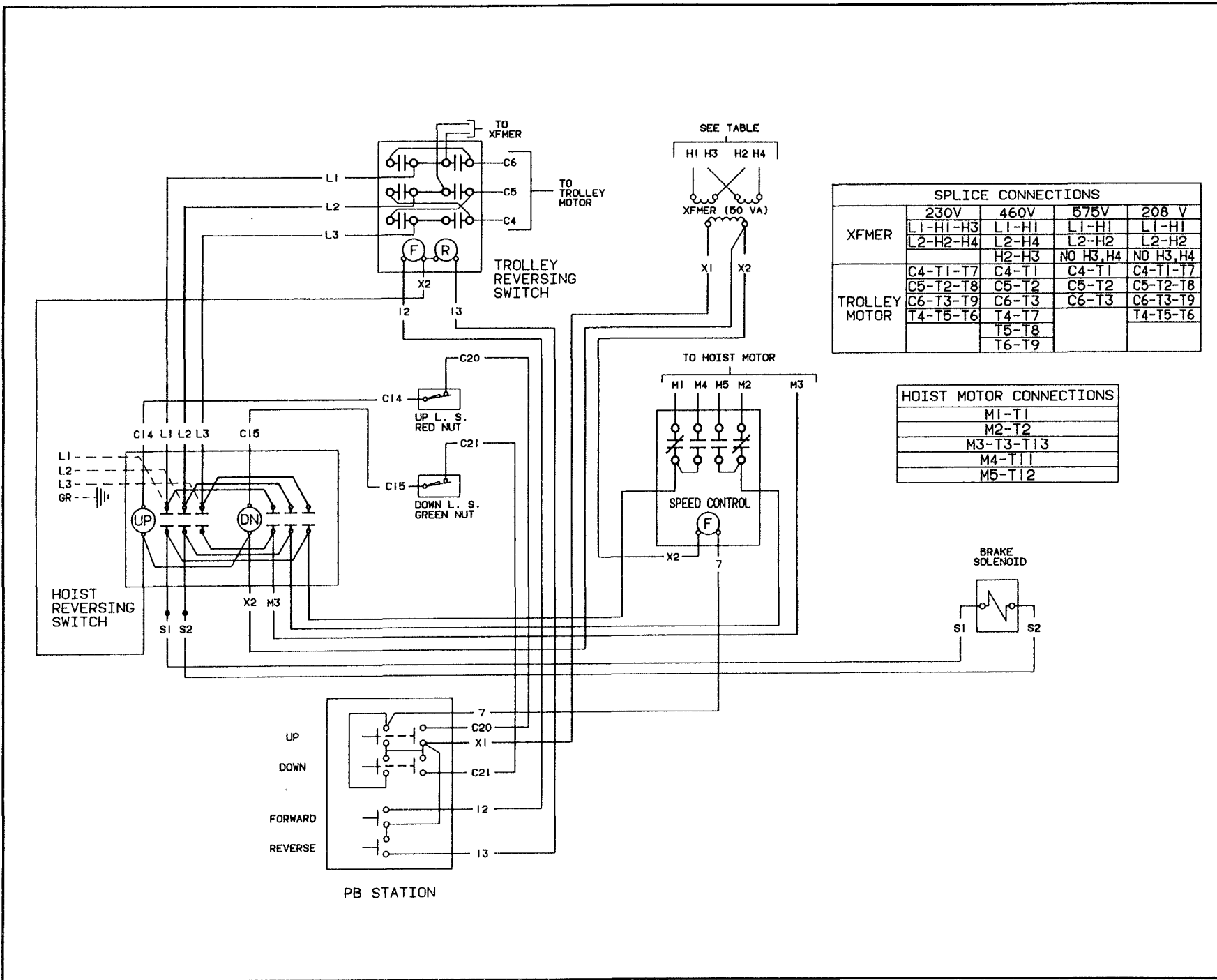

FIGURE 7-3. WIRING DIAGRAM
208, 230/460, and 575V, 3 Phase
Single Speed Hoist and Single Speed Trolley
985 WRMT 1

FIGURE 7-4. WIRING DIAGRAM
230, 460, 575, and 208V, 3 Phase
Two Speed Hoist and Single Speed Trolley
985 WRRMT 2



TRANSFORMER CONNECTIONS

230V	460V	208, 575V
L1-H1-H3	L1-H1	L1-H1
L2-H2-H4	L2-H4	L2-H2
	H2-H3	NO H3, H4

MOTOR CONNECTIONS

HOIST MOTOR			TROLLEY MOTOR
208, 230V.	460V.	575V.	C1-T1
M1-T1-T7	M1-T1	M1-T1	C2-T2
M2-T2-T8	M2-T2	M2-T2	C4-T11
M3-T3-T9	M3-T3	M3-T3	C5-T12
T4-T5-T6	T4-T7		C6-T3-T13
	T5-T8		
	T6-T9		

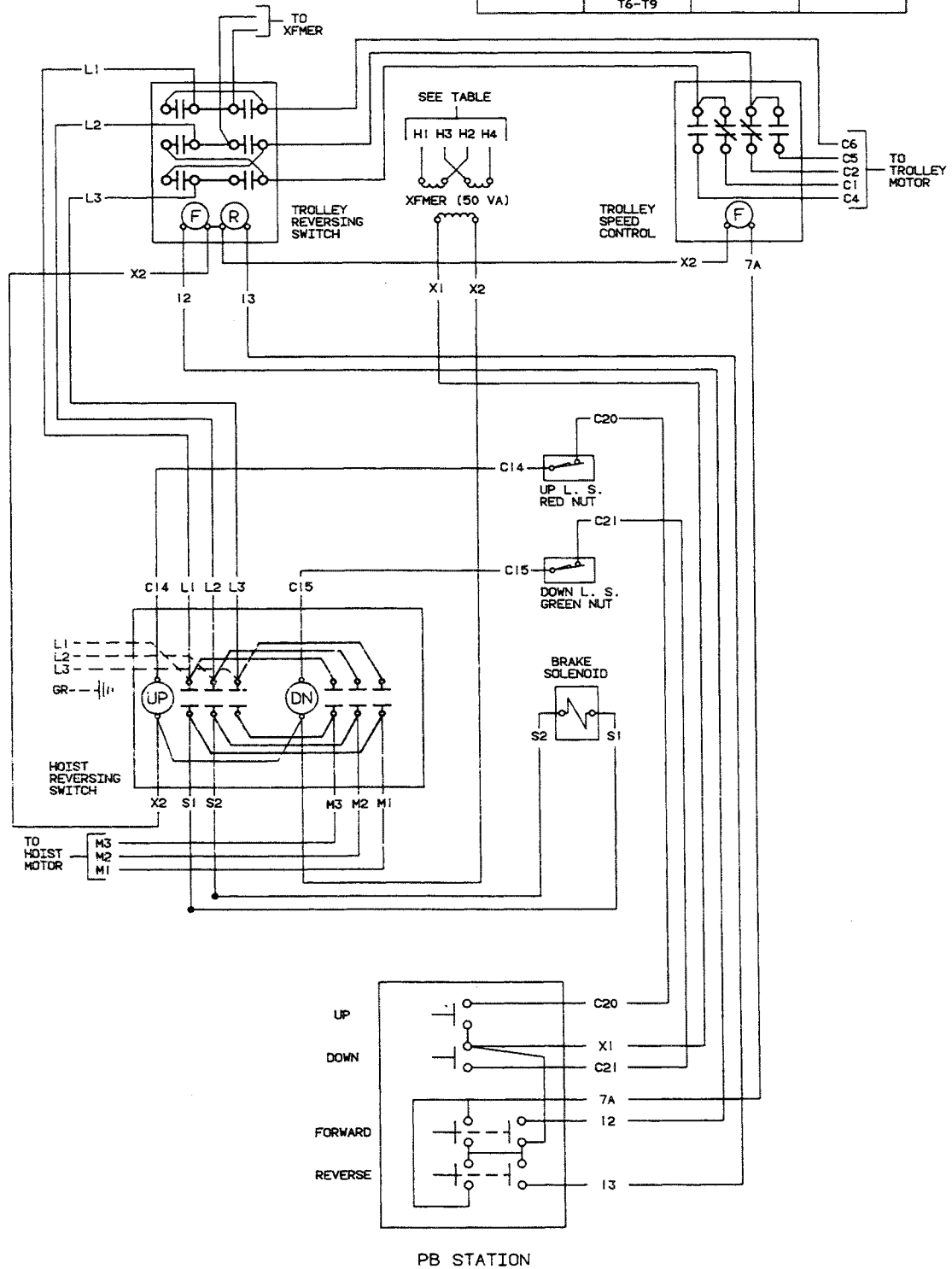

**FIGURE 7-5. WIRING DIAGRAM
230, 460, 575, and 208V, 3 Phase
Single Speed Hoist and Two Speed Trolley
985 WRMT 3**

TRANSFORMER CONNECTIONS		
230V	460V	208, 575V
L1-H1-H3	L1-H1	L1-H1
L2-H2-H4	L2-H4	L2-H2
	H2-H3	NO H3, H4

MOTOR CONNECTIONS	
HOIST MOTOR	TROLLEY MOTOR
M1-T1	C1-T1
M2-T2	C2-T2
M3-T3-T13	C4-T11
M4-T11	C5-T12
M5-T12	C6-T3-T13

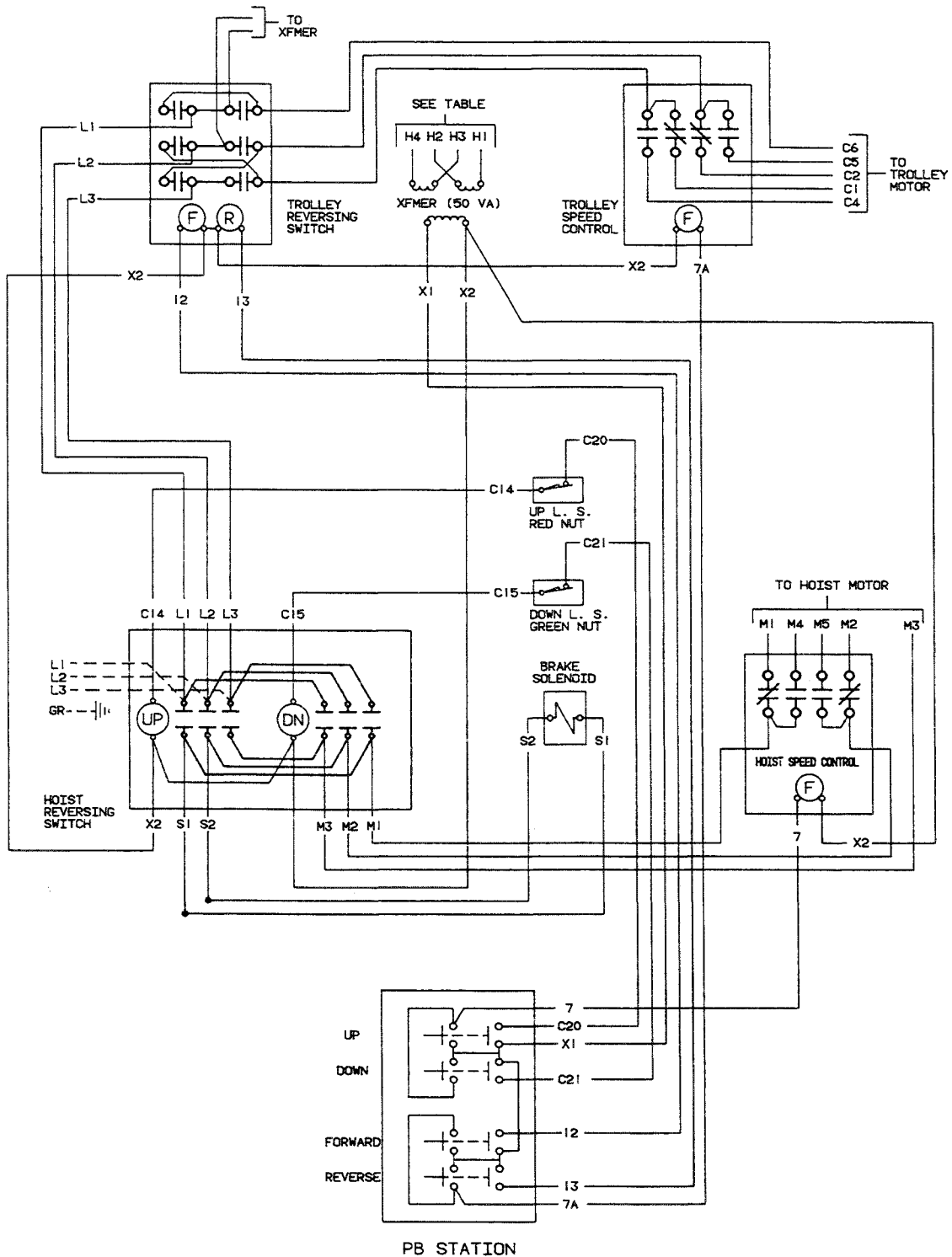

**FIGURE 7-6. WIRING DIAGRAM
230, 460, 575, and 208V, 3 Phase
Two Speed Hoist and Two Speed Trolley
985 WRMT 4**

SECTION VIII ILLUSTRATED PARTS LIST

8-1. General

The following exploded drawings provide a complete list of parts used in the standard WR-5 hoist models (shown in Table 1-1, page 1). Since several different models of hoists are covered by this manual, differences may be noted between the appearance of your hoist part and the reference illustration. If this is the case, the parts list will show several different part numbers with sufficient information to allow the selection of the correct part number.

8-2. How To Use The Parts List

The parts list consists of three columns as follows:

- 1) Index Number
- 2) Part Name, and additional descriptions which are essential for choosing the correct part number when more than one is listed.
- 3) Part Number

b. How to determine proper part number.

- 1) Locate the index number in the corresponding figure of the parts list.
- 2) If only one part number is listed for the index number, that part number should be ordered.
- 3) If more than one part number is listed, the information under "part name" will determine the correct part number.

EXAMPLE

Index No.	Part Name	Part No.
4	Transformer; 230/460V Primary, 115V Secondary: Single Speed Hoist Two Speed Hoist ... etc. . .	JF-821 821J4 ...etc. . .

8-3. How To Order Replacement Parts

When ordering parts or requesting information concerning your WR hoist, always include the hoist model number and serial number. Both numbers are permanently stamped on the hoist nameplate located on the motor-side frame plate.

When ordering motor parts, please provide complete motor nameplate data, including motor "ref." number or model number.

NOTE

Repair parts are available only from Coffing distributors or authorized repair facilities. It is recommended that repair part orders be directed to the authorized repair facility nearest you.

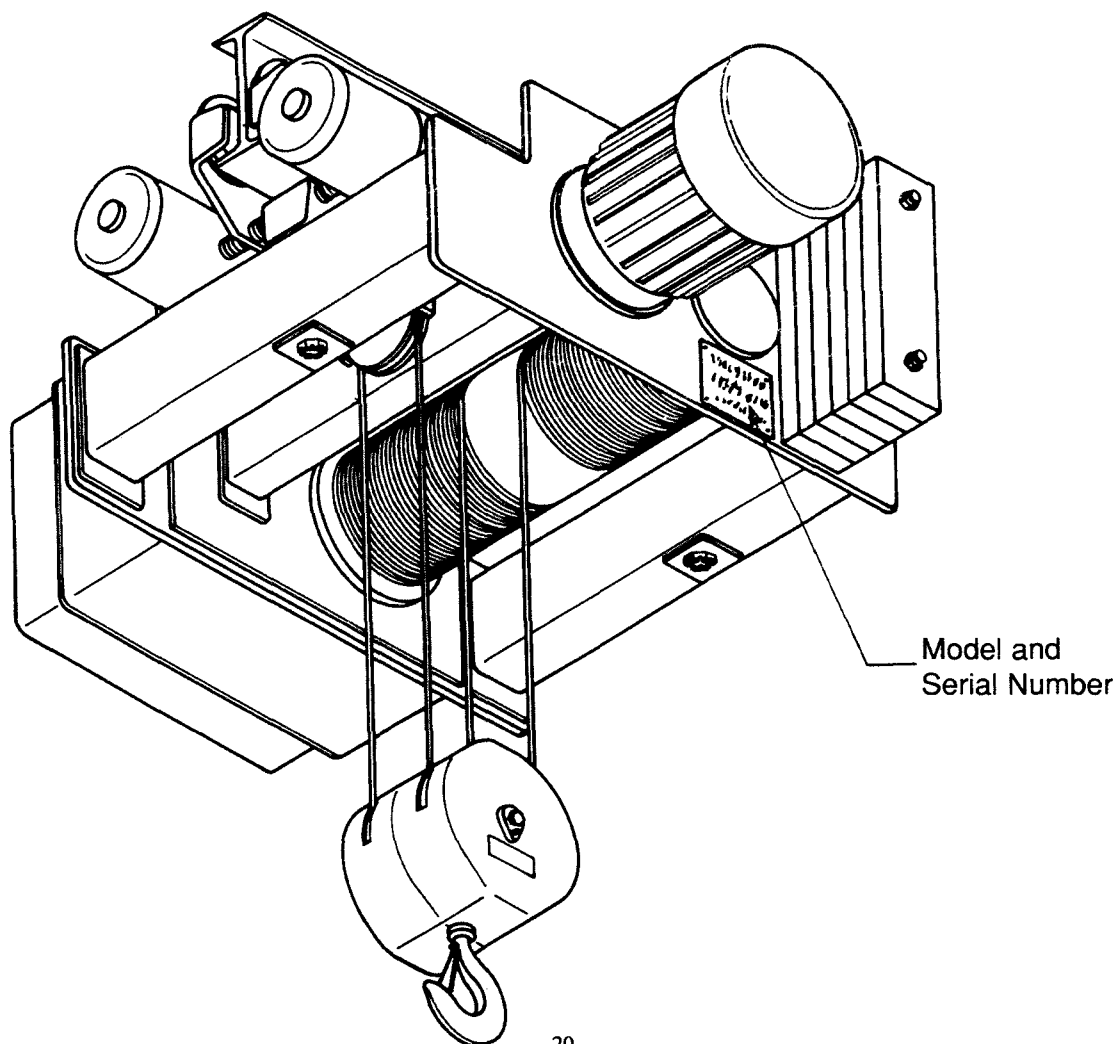

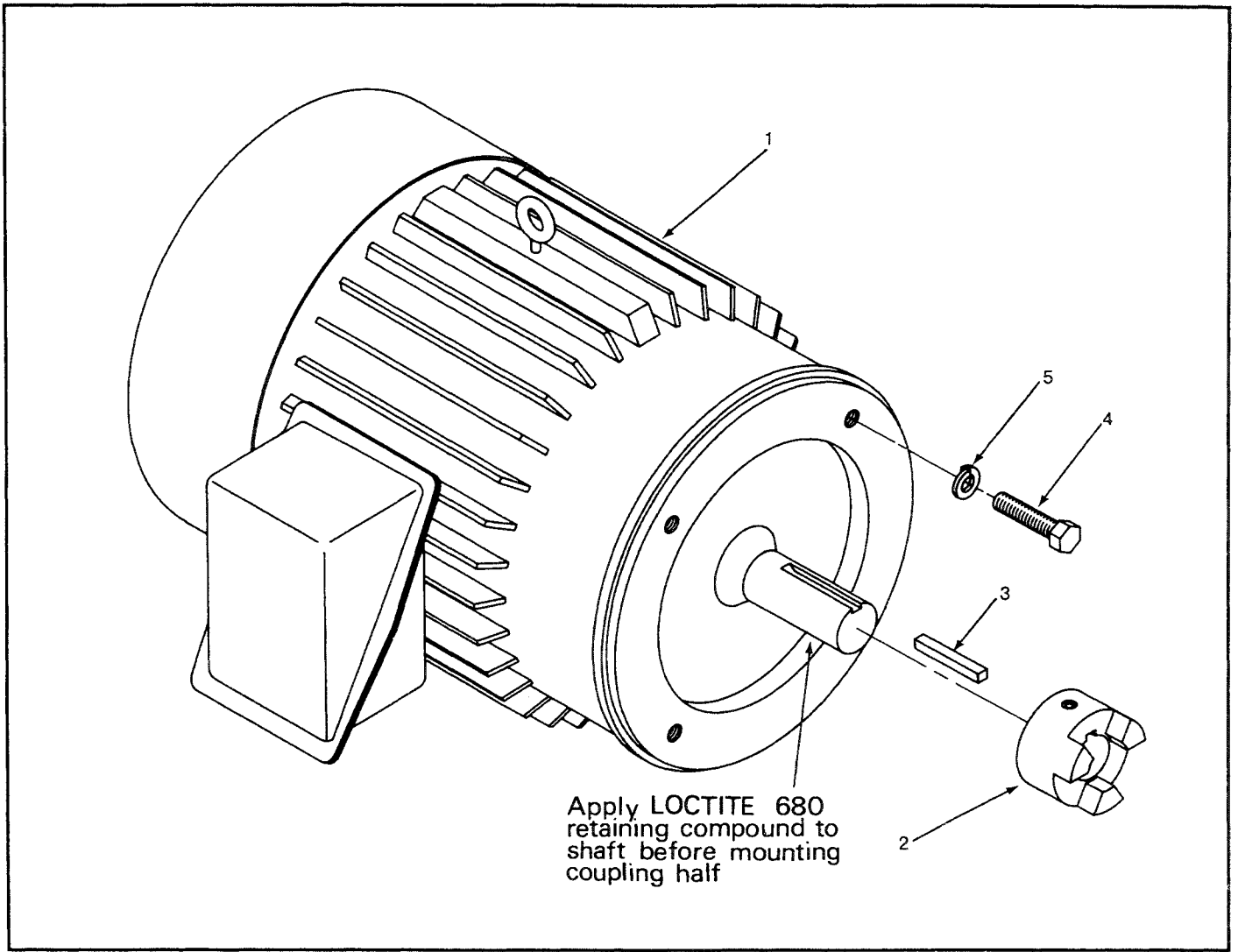

Index No.	Part Name	Part No.
1	Motor, Single-Speed, Complete:	
	208, 230/460V, 3 Ph.	863J502
	575V, 3 Ph.	863J503
	Motor, Two-Speed, Complete:	
208, 230V, 3 Ph.	873J502	
460V, 3 Ph.	873J503	
575V, 3 Ph.	873J504	

Index No.	Part Name	Part No.
2	Coupling Half	107J13-1
3	Key	H-4257
4	Screw	S-44-93
5	Lockwasher	H-4083-P

FIGURE 8-1. HOIST MOTOR

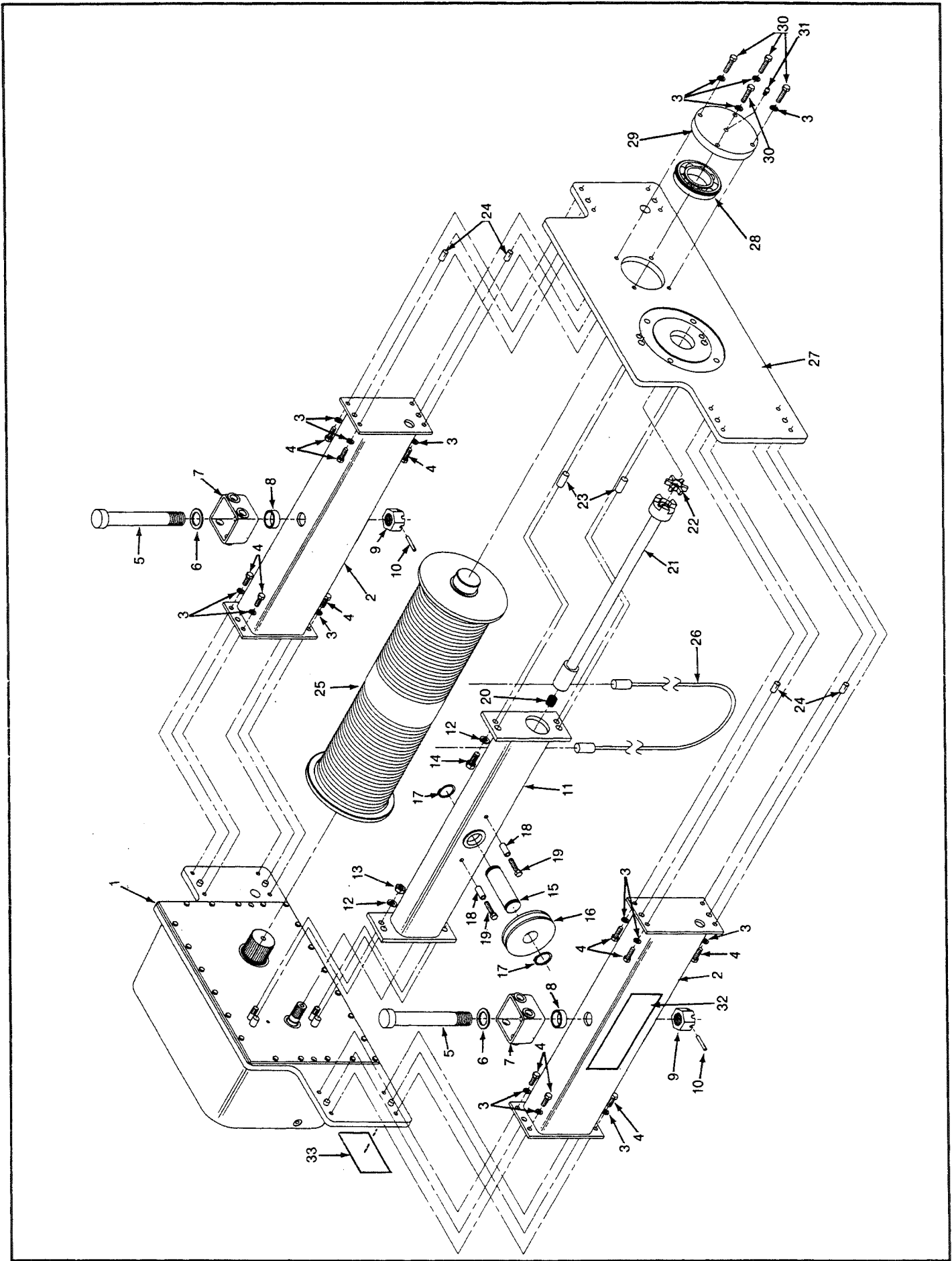

FIGURE 8-2. DRUM AREA (20 FT. LIFT)

Index No.	Part Name	Part No.
1	Transmission Assembly	See Fig. 8-4
2	Tube Assembly (Suspension)	200JG50-1
3	Lockwasher	H-4085-P
4	Screw	S-44-41
5	Kingbolt	700J10
6	Washer	255K25
7	Suspension Box	50J44
8	Spacer	200J52
9	Slotted Nut	H-3925-P
10	Driv-Lok Pin	H-5230-10
11	Tube Assembly (Eq. Sheave)	200JG51-1
12	Lockwasher	H-4083-P
13	Nut	S-12-27
14	Screw	H-2314
15	Eq. Sheave Pin	122J24
16	Equalizer Sheave	28J18
17	Retaining Ring	H-5577
18	Rope Guard	230J9

Index No.	Part Name	Part No.
19	Screw	S-44-44
20	Spring	340J9
21	Coupling Assembly	108JG6-1
22	Spider	107J13-3
23	Dowel Pin	H-5410
24	Driv-Lok Pin	H-5230-5
25	Drum Assembly	16JG22-1
26	Wire Rope Assembly	19J401
27	Motor Plate	48J11
28	Bearing	500J3
29	Bearing Cap	32J4
30	Screw	S-44-43
31	Grease Fitting	SK-974-32
32	Capacity Decal:	
	3 Ton	675J17
	5 Ton	675J18
33	Duff-Norton Decal	676J2B

FIGURE 8-2. DRUM AREA (20 FT. LIFT)

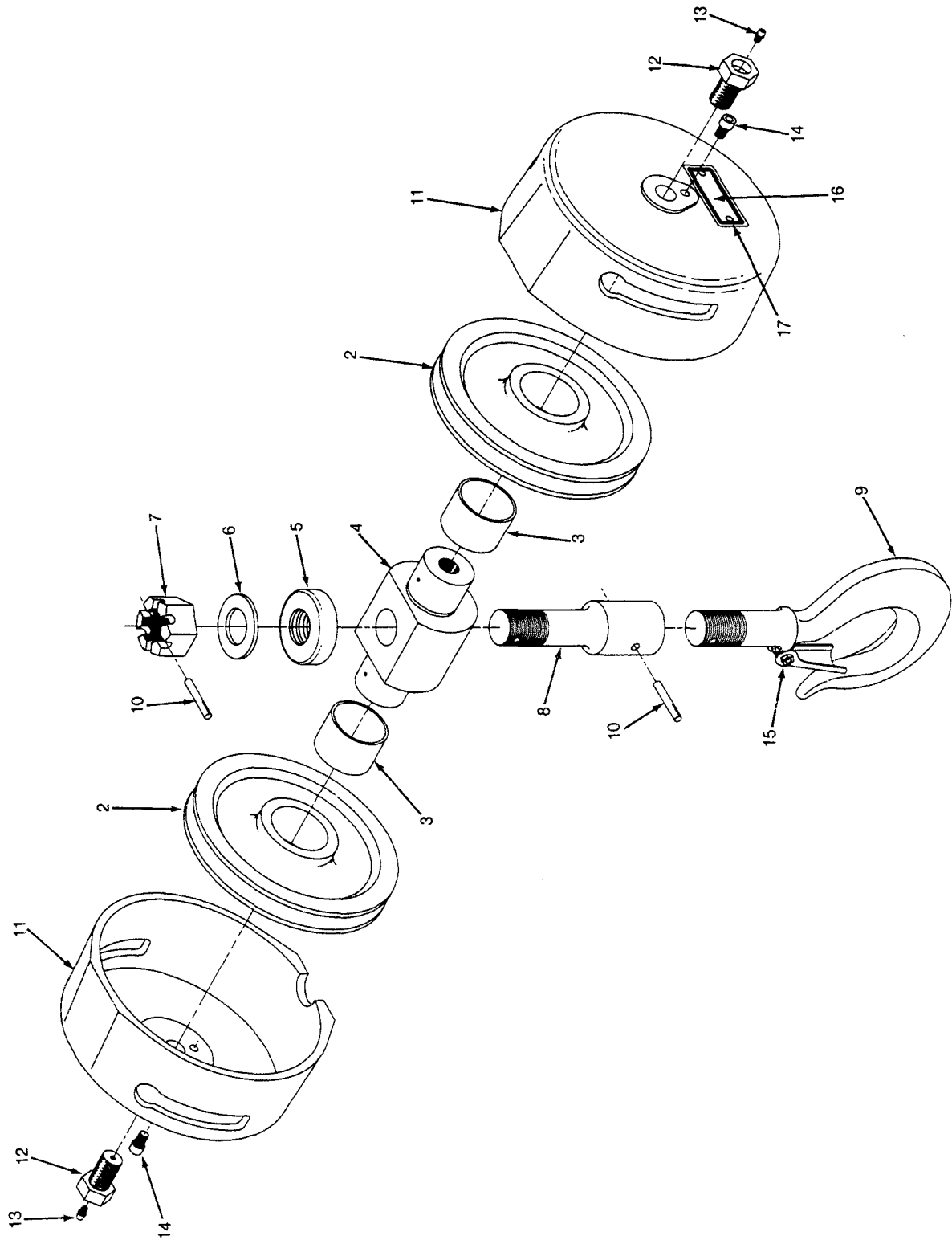

FIGURE 8-3. BOTTOM BLOCK

Index No.	Part Name	Part No.
1	Bottom Block Assembly, Complete (Consists of Index No. 2 thru 14)	914B6R
2	Sheave	28J17
3	Sheave Bearing	530J37
4	Yoke	122J23
5	Thrust Bearing	CB-511-1
6	Washer	CB-252-3
7	Slotted Nut	H-3925-P
8	Shank Extension	124J13
9	Hook and Latch Assembly	SHL-15

Index No.	Part Name	Part No.
10	Driv-Lok Pin	H-5230-10
11	Cover	30J26
12	Screw	718J1
13	Grease Fitting	H-7900
14	Screw	H-2234
15	Latch Kit	H-7545
16	Capacity Plate:	
	3 Ton	675K39
	5 Ton	675K42
17	Drive Rivet	S-40-28

FIGURE 8-3. BOTTOM BLOCK

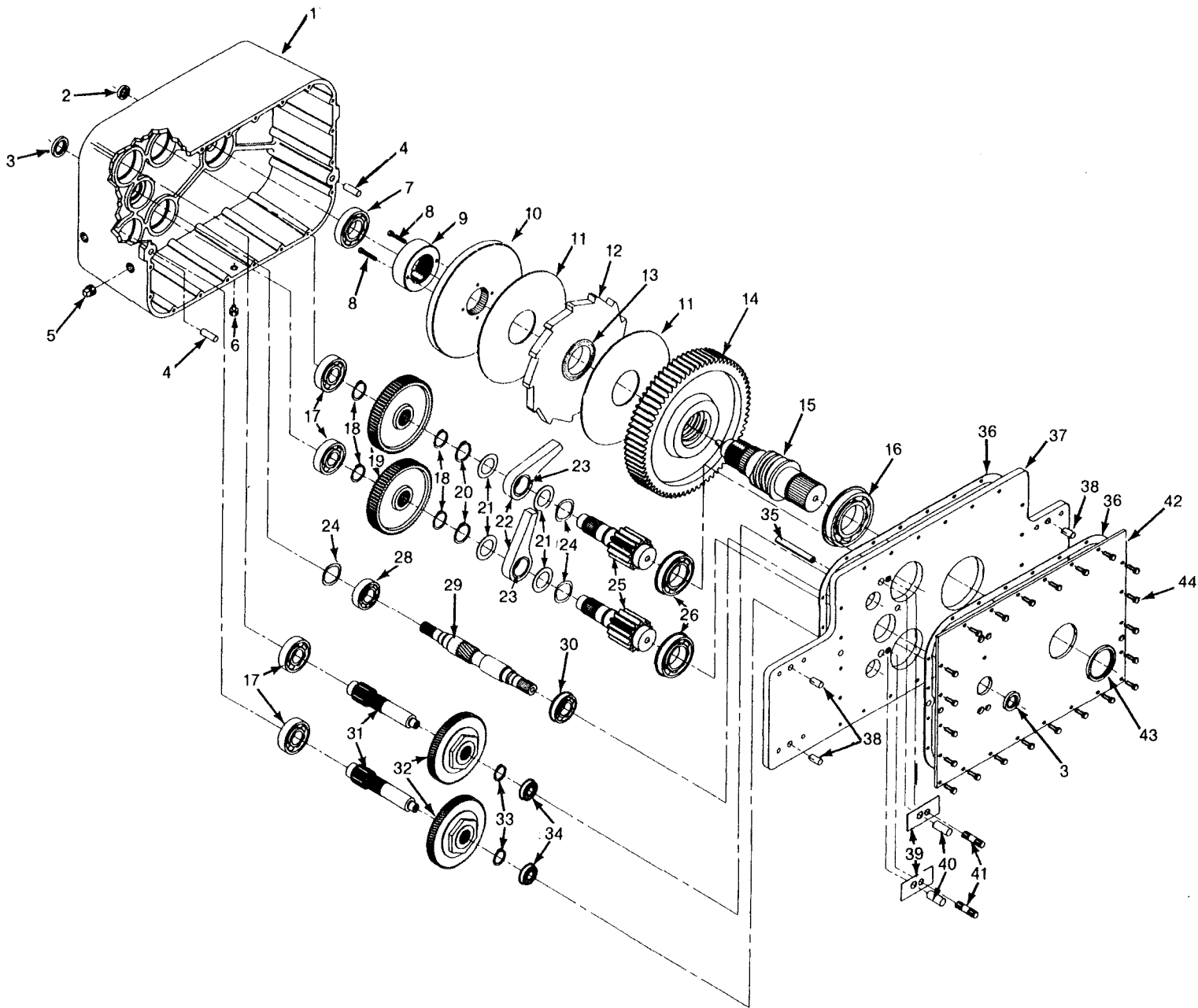

FIGURE 8-4. HOIST TRANSMISSION

Index No.	Part Name	Part No.
1	Gear Housing	35J7
2	Oil Seal	561K2
3	Oil Seal	561J1
4	Dowel Pin	H-5408
5	Fill Plug	H-6253
6	Drain Plug	H-6268
7	Bearing	500K15
8	Screw	S-49-10
9	Load Brake Nut	130J10
10	Pressure Plate	5J10
11	Friction Disc	580J10
12	Ratchet	7J17
13	Bearing	521J2
14	Output Gear	405J3
15	Output Shaft	132JG24
16	Bearing	500J4
17	Bearing	SE-501-4
18	Retaining Ring	H-5540
19	Intermediate Gear:	
	WR-6026	403J6
	WR-10016	403J14
20	Retaining Ring	H-5572
21	Thrust Washer	255K30
22	Pawl	25J3

Index No.	Part Name	Part No.
23	Bearing	530J38
24	Wave Washer	360J3
25	Output Pinion	404J6
26	Bearing	500J2
28	Bearing	500K16
29	Input Pinion	400J10
30	Bearing	500J1
31	Intermediate Pinion:	
	WR-6026	402J15
	WR-10016	402J14
32	Slip Clutch Assembly	591JG26
33	Retaining Ring	H-5575
34	Bearing	500K8
35	Roll Pin	H-5272
36	Gasket	560J14
37	Transmission Frame	48J10
38	Driv-Lok Pin	H-5230-5
39	Shim Gasket	560J15
40	Dowel Pin	H-5410
41	Stud	141J15
42	Seal Plate	278J1
43	Oil Seal	561J2
44	Screw	H-2307

FIGURE 8-4. HOIST TRANSMISSION

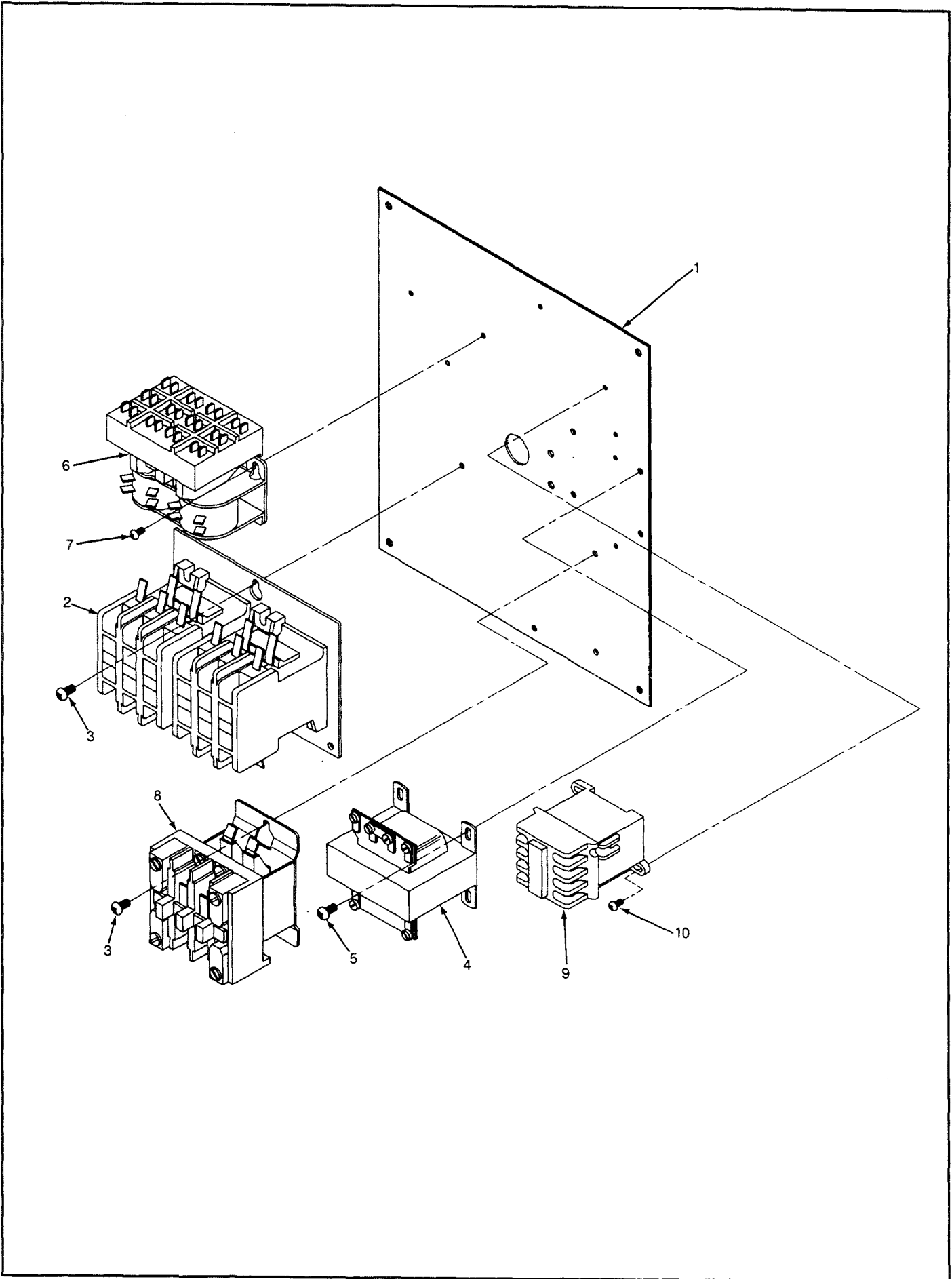

FIGURE 8-5. CONTROL PANEL

Index No.	Part Name	Part No.
1	Panel Plate	257J100
2	Hoist Reversing Contactor	820J9
3	Screw	H-2981-P
4	Transformer; 230/460V Primary, 115V Secondary:	
	Single Speed Hoist	JF-821
	Two Speed Hoist	821J4
	Single Speed Hoist-Single Speed Trolley	JF-821-17
	Two Speed Hoist - Single Speed Trolley	821J4
	Single Speed Hoist-Two Speed Trolley	821J4
	Two Speed Hoist-Two Speed Trolley	821J4
	Transformer; 208V Primary, 115V Secondary:	
	Single Speed Hoist	JF-821
	Two Speed Hoist	821J8
	Single Speed Hoist-Single Speed Trolley	JF-821-17
	Two Speed Hoist-Single Speed Trolley	821J8
	Single Speed Hoist-Two Speed Trolley	821J8
	Two Speed Hoist-Two Speed Trolley	821J8

Index No.	Part Name	Part No.
	Transformer: 575V Primary, 115V Secondary:	
	Single Speed Hoist	JF-821-2
	Two Speed Hoist	821J6
	Single Speed Hoist-Single Speed Trolley	JF-821-20
	Two Speed Hoist-Single Speed Trolley	821J6
	Single Speed Hoist-Two Speed Trolley	821J6
	Two Speed Hoist-Two Speed Trolley	821J6
5	Screw: for JF-821-series transformers for 821J-series transformers	H-2751 H-2981-P
6	Trolley Reversing Contactor (units with motorized trolley only)	820K317
7	Screw	H-2751
8	Hoist Speed Control Relay (two speed hoists only)	820J11
9	Trolley Speed Control Relay (two speed trolleys only)	820J4
10	Screw	H-2752

FIGURE 8-5. CONTROL PANEL (115 Volt Control)

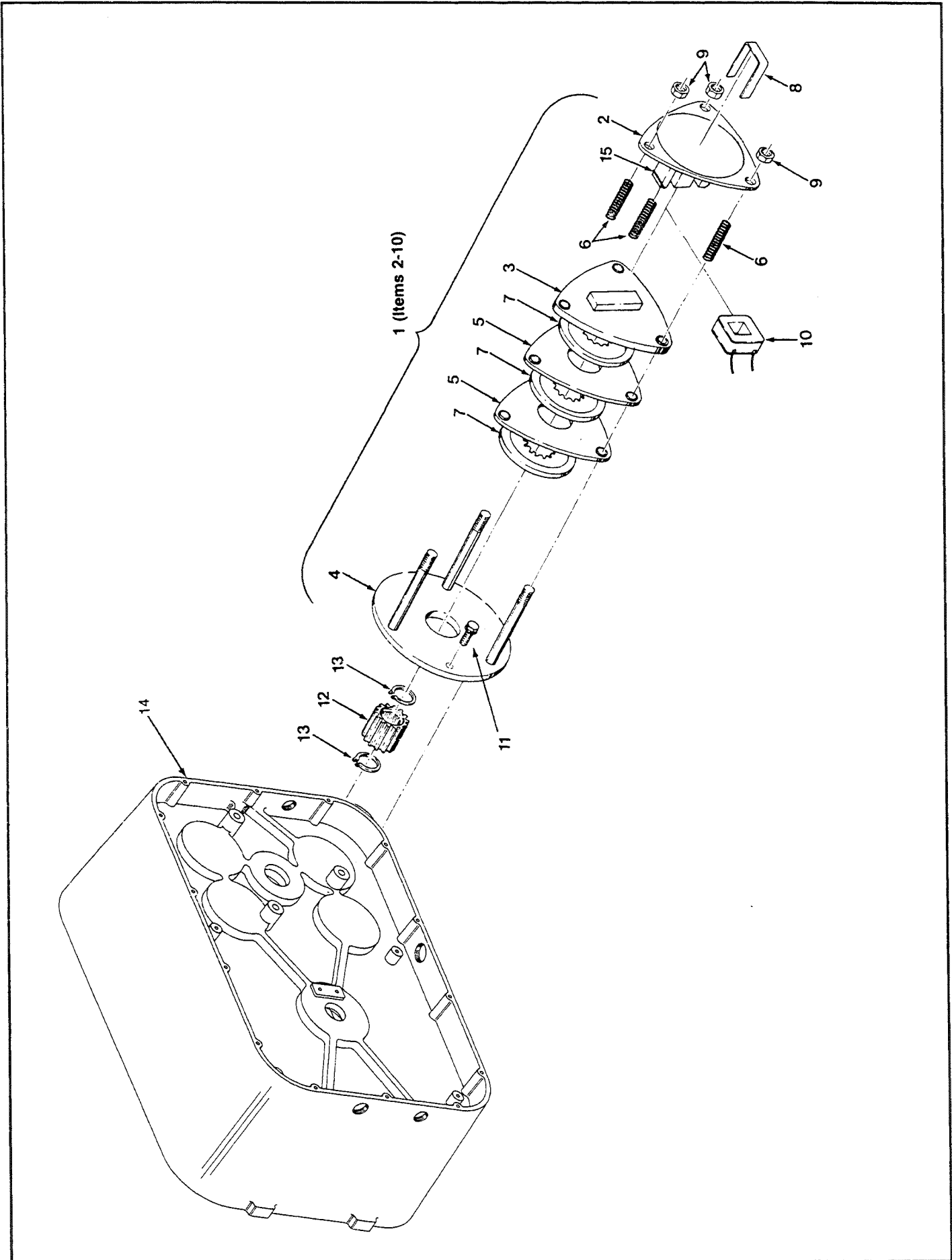

FIGURE 8-6. MOTOR BRAKE

Index No.	Part Name	Part No.
1	Disc Brake Assembly: (Consists of Index No. 2 thru 10) Single Speed Hoists: 230/460V, 3 Ph, 60 Hz 575V, 3 Ph, 60 Hz 208V, 3 Ph, 60 Hz Two Speed Hoists: 230V, 3 Ph, 60 Hz 460V, 3 Ph, 60 Hz 575V, 3 Ph, 60 Hz 208V, 3 Ph, 60 Hz	854JG30 854JG32 854JG33 854JG30 854JG31 854JG32 854JG33
2	Plate and Frame Assembly	291JG8
3	Plate and Armature Assembly	291JG9
4	Plate and Stud Assembly	290JG4
5	Brake Plate	291J10

Index No.	Part Name	Part No.
6	Spring	344J7
7	Brake Disc Assembly	581JG2
8	Retainer	JF-710
9	Lock Nut	H-3978
10	Coil: 230V, 60 Hz (For Brake 854JG30) 460V, 60 Hz (For Brake 854JG31) 575V, 60 Hz (For Brake 854JG32) 208V, 60 Hz (For Brake 854JG33)	JF-853-2 JF-853-3 JF-853-4 JF-853-5
11	Screw	H-2988-P
12	Brake Adapter	142J2
13	Retaining Ring	H-5527
14	Transmission Housing	See Fig. 8-4
15	Shading Coil Element (Must be attached to frame with H-7812 adhesive)	860J1
16	Adhesive (1 oz. tube)	H-7812

FIGURE 8-6. MOTOR BRAKE

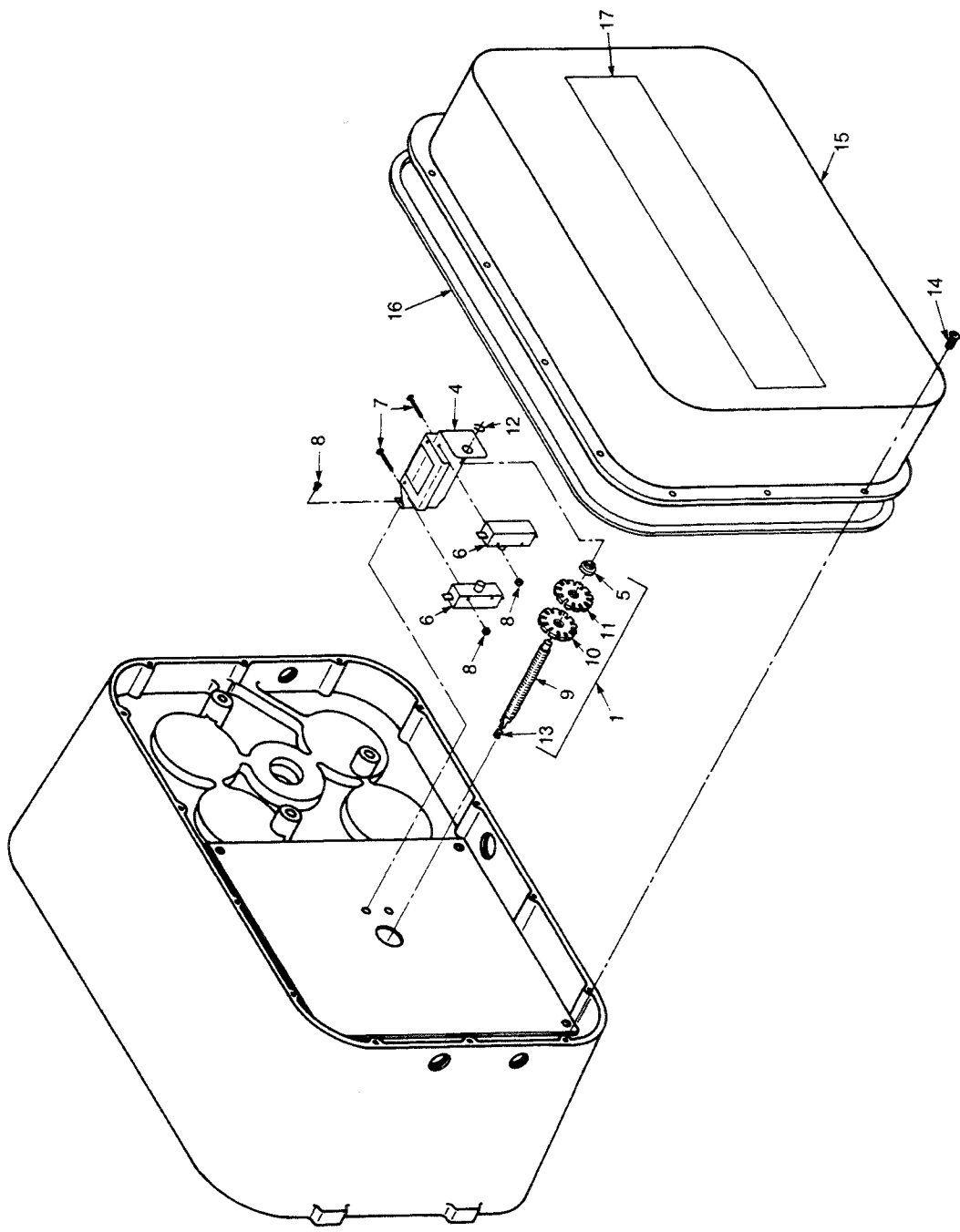

FIGURE 8-7. LIMIT SWITCH

Index No.	Part Name	Part No.
1	Limit Switch and Shaft Assembly (Consists of Index No. 4 thru 12)	918JG7
4	Limit Switch Bracket Assembly (Includes Index No. 5)	JF-900-3
5	Limit Switch Bushing	JF-531-4
6	Microswitch	815J1
7	Screw	H-1402-P
8	Nut	H-3944
9	Limit Switch Shaft	JF-117-3

Index No.	Part Name	Part No.
10	Limit Switch Nut (Red)	JF-751-3R
11	Limit Switch Nut (Green)	JF-751-3G
12	Retaining Ring	H-5520
13	Spring	JF-343-3
14	Screw	H-2981-P
15	Control Cover	36J12
16	Weatherstrip (6 ft. required)	560K8
17	Coffing® Decal	677J8

FIGURE 8-7. LIMIT SWITCH

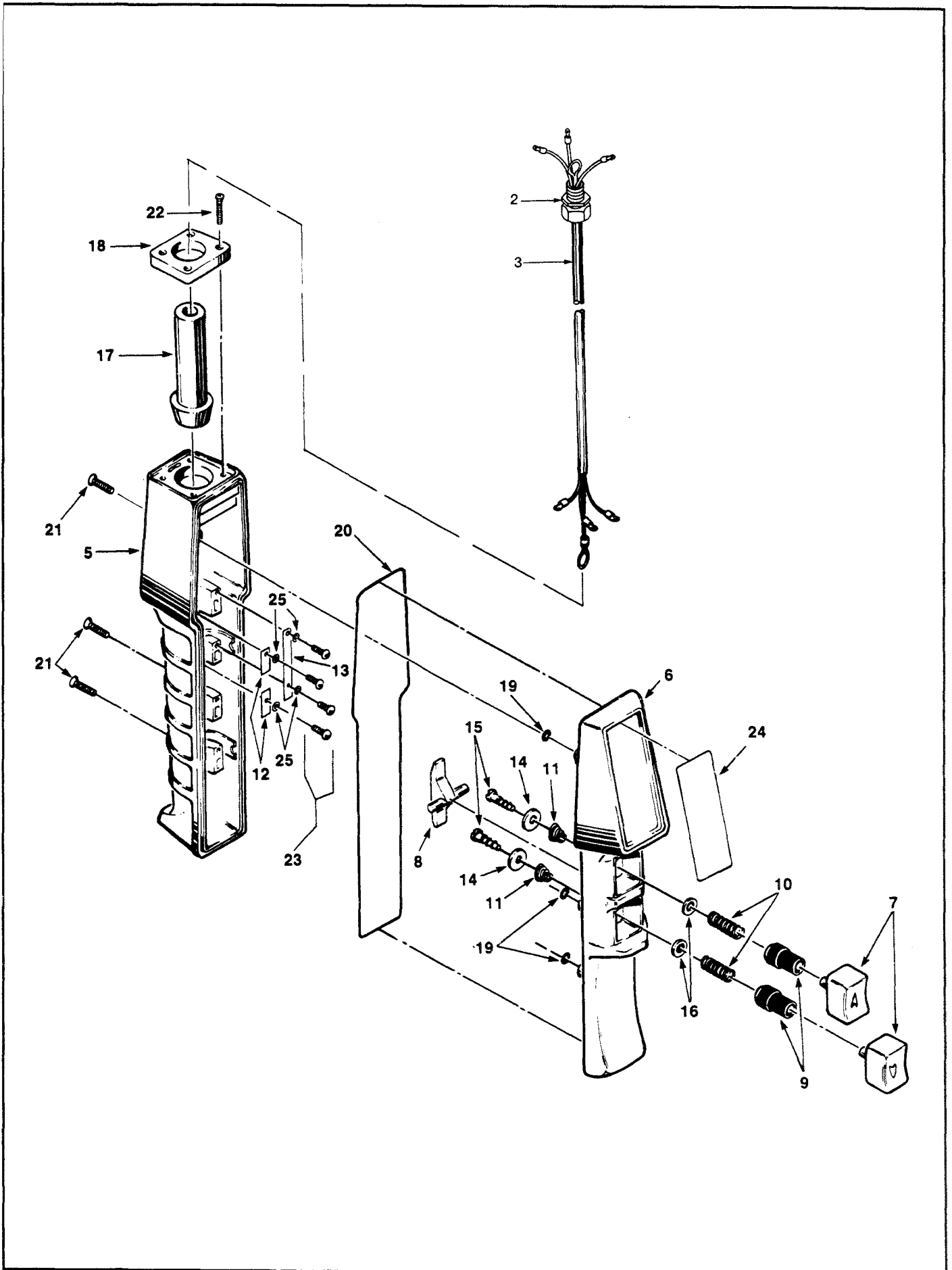

FIGURE 8-8A. PUSHBUTTON (SINGLE SPEED HOISTS)

Index No.	Part Name	Part No.
2	Connector	H-7609
3	Push Button Cable Assembly: 16 ft. Drop	299JG3-16
	Special Length Drop (*Equal to P.B. Drop)	299JG3.*
4	Push Button Assembly (Consists of Index Nos. 5 thru 25)	534K97-B
5	Enclosure	PB-282-4
6	Cover	PB-298
7	Push Button	PB-284-2
8	Interlock (Single-speed, Red)	PB-285
9	Boot	PB-286
10	Spring, Compression	PB-287
11	Spring, Conical	PB-288
12	Contact Plate	PB-289

Index No.	Part Name	Part No.
13	Contact Plate, Common	PB-290
14	Washer, Contact	PB-291
15	Screw	PB-301
16	Washer, Boot	PB-293
17	Grommet	PB-294-1
18	Cap, Enclosure	PB-295
19	"O" Ring	X-6477-1
20	Rubber Seal	H-7851
21	Screw	H-2991
22	Screw	H-2992
23	Screw	H-2993
24	Warning Tag	PB-296
25	Lock Washer	H-4160

FIGURE 8-8A. PUSHBUTTON (SINGLE SPEED HOISTS)

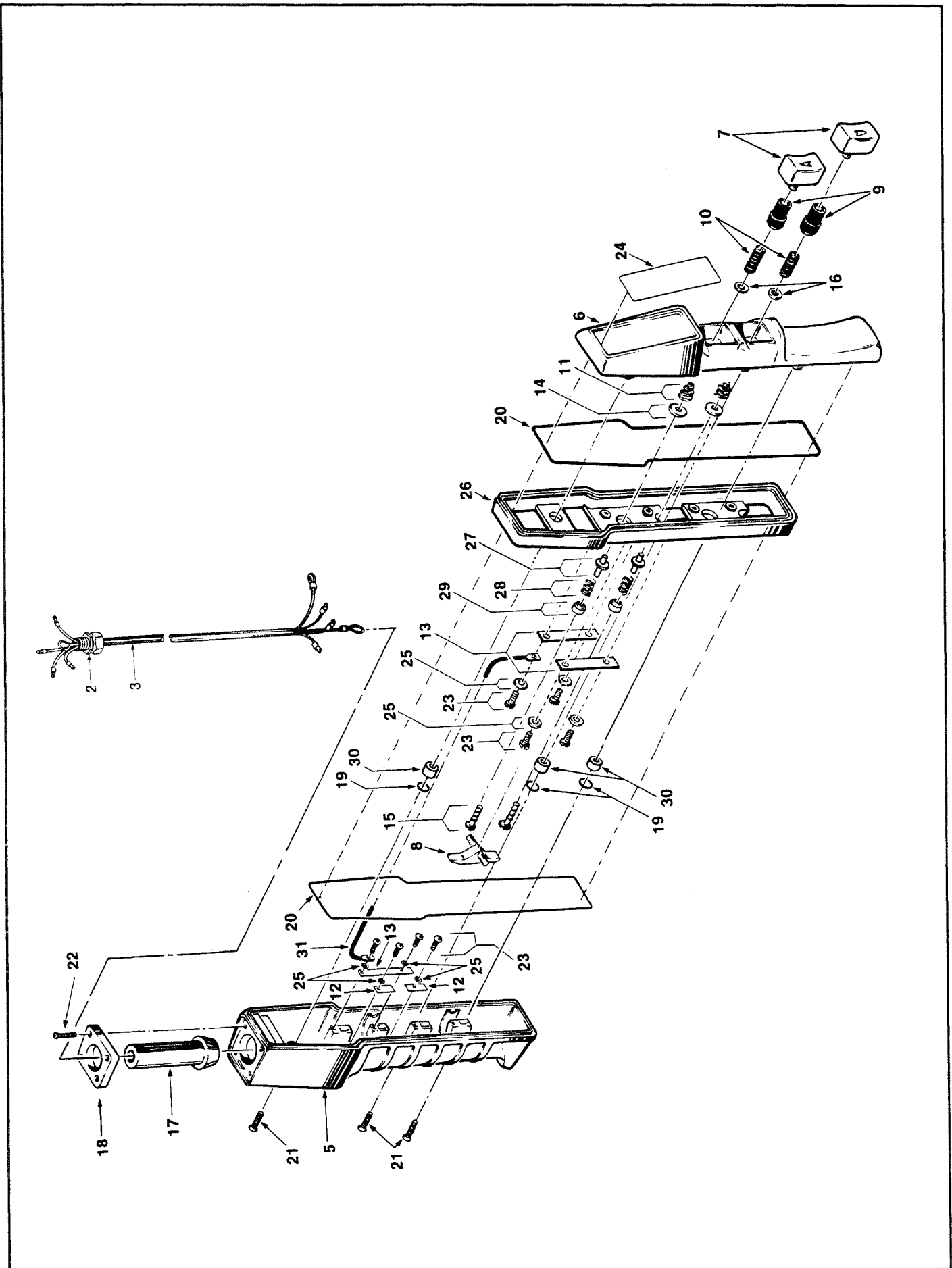

FIGURE 8-8B. PUSHBUTTON (TWO SPEED HOISTS)

Index No.	Part Name	Part No.
2	Connector	H-7609
3	Push Button Cable Assembly: 16 ft. Drop	PB-300-16
4	Special Length Drop (*Equal to P.B. Drop) Push Button Assembly (Consists of Index Nos. 5 thru 31)	PBS-300- 534JG4
5	Enclosure	PB-282-4
6	Cover	PB-298
7	Push Button	PB-284-2
8	Interlock (Two-speed, Black)	PB-285-1
9	Boot	PB-286
10	Spring, Compression	PB-287
11	Spring, Conical	PB-288
12	Contact Plate	PB-289
13	Contact Plate, Common	PB-290
14	Washer, Contact	PB-291
15	Screw	H-1852-P

Index No.	Part Name	Part No.
16	Washer, Boot	PB-293
17	Grommet	PB-294-2
18	Cap, Enclosure	PB-295
19	"O" Ring	X-6477-1
20	Rubber Seal	H-7851
21	Screw (Enclosure)	H-2925
22	Screw (Cap)	H-2992
23	Screw (Plates)	H-2993
24	Warning Tag	PB-296
25	Lock Washer	H-4160
26	2-Speed Adapter	PB-308
27	Insulating Bushing	755J1
28	Spring Lower	344J5
29	Contact Button	201J1
30	Bushing	200J16
31	Jumper Wire	JF-940-42

FIGURE 8-8B. PUSHBUTTON (TWO SPEED HOISTS)

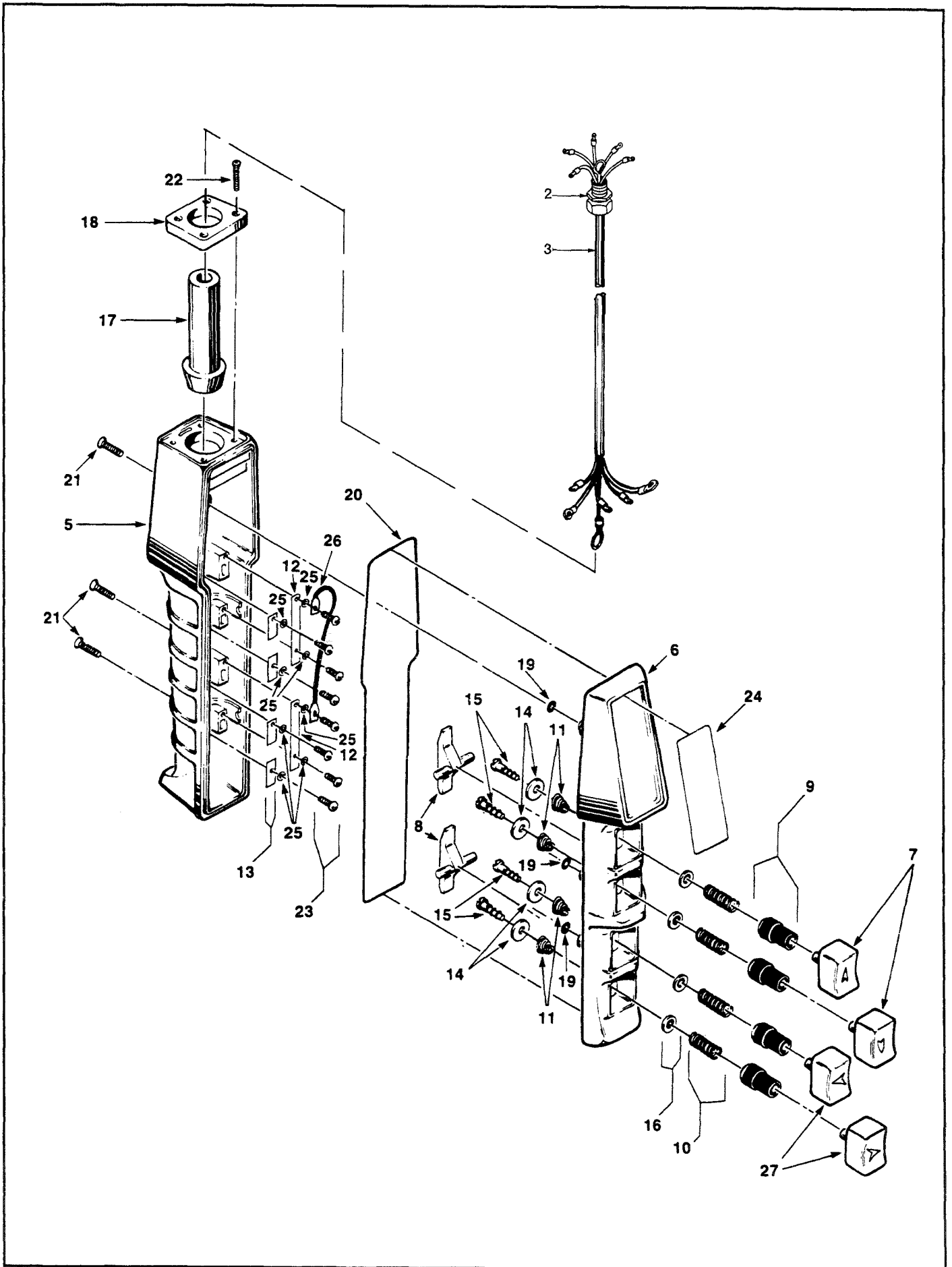
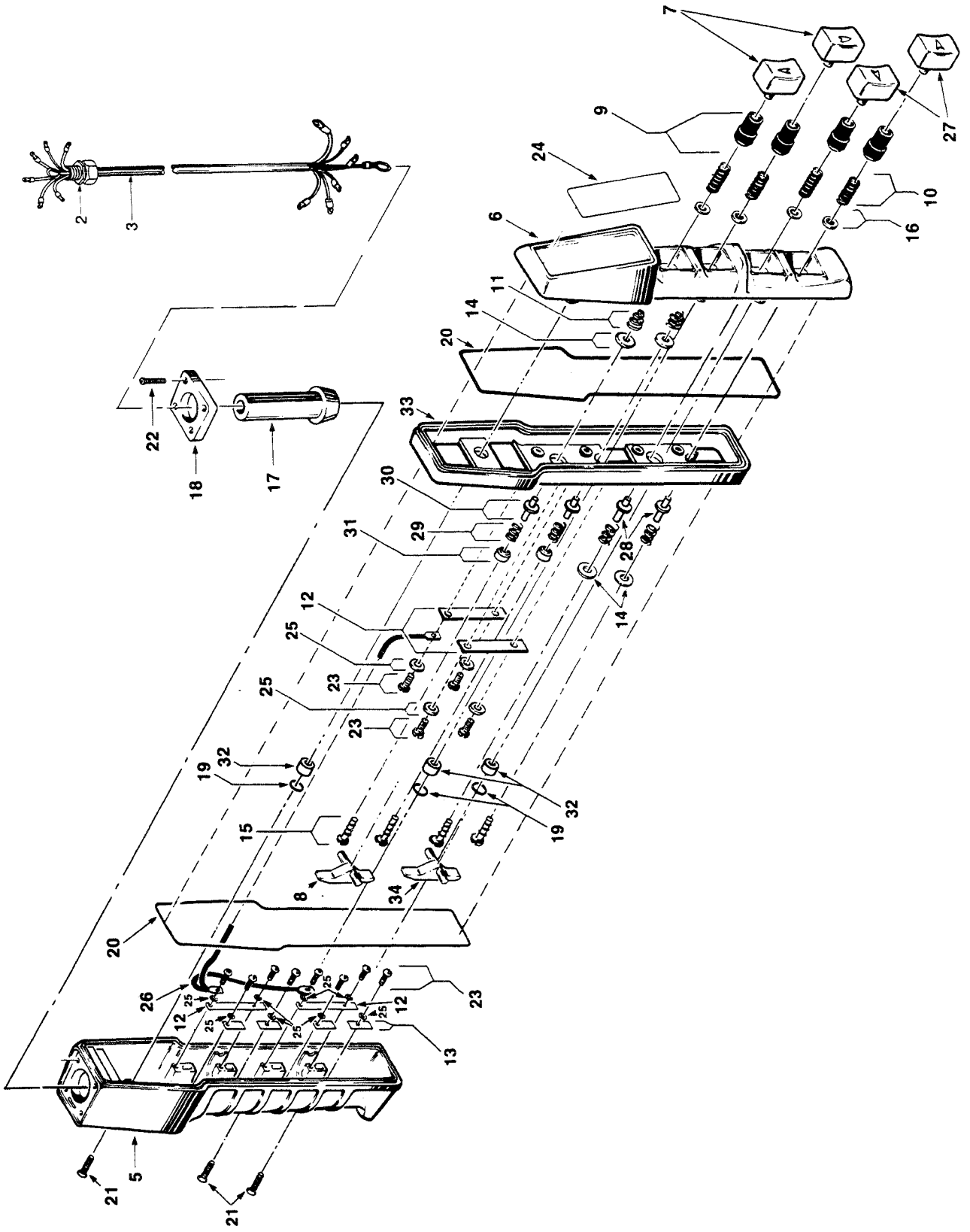

FIGURE 8-8C. PUSHBUTTON (SINGLE SPEED HOIST - SINGLE SPEED TROLLEY)

Index No.	Part Name	Part No.
2	Connector	H-7609
3	Push Button Cable Assembly: 16 ft. Drop	300JG1-16
	Special Length Drop (*Equal to P.B. Drop)	300JG1-*
4	Push Button Assembly (Consists of Index Nos. 5 thru 27)	534K98
5	Enclosure	PB-282-4
6	Cover	PB-283
7	Push Button (Hoist)	PB-284-2
8	Interlock (Single-speed, Red)	PB-285
9	Boot	PB-286
10	Spring, Compression	PB-287
11	Spring, Conical	PB-288
12	Contact Plate, Common	PB-290
13	Contact Plate	PB-289

Index No.	Part Name	Part No.
14	Washer, Contact	PB-291
15	Screw	PB-301
16	Washer, Boot	PB-293
17	Grommet	PB-294-2
18	Cap, Enclosure	PB-295
19	"O" Ring	X-6477-1
20	Seal	H-7851
21	Screw	H-2991
22	Screw	H-2992
23	Screw	H-2993
24	Warning Tag	PB-296
25	Lock Washer	H-4160
26	Jumper (Common)	JF-940-42
27	Push Button (Trolley)	PB-284-1

FIGURE 8-8C. PUSHBUTTON (SINGLE SPEED HOIST - SINGLE SPEED TROLLEY)

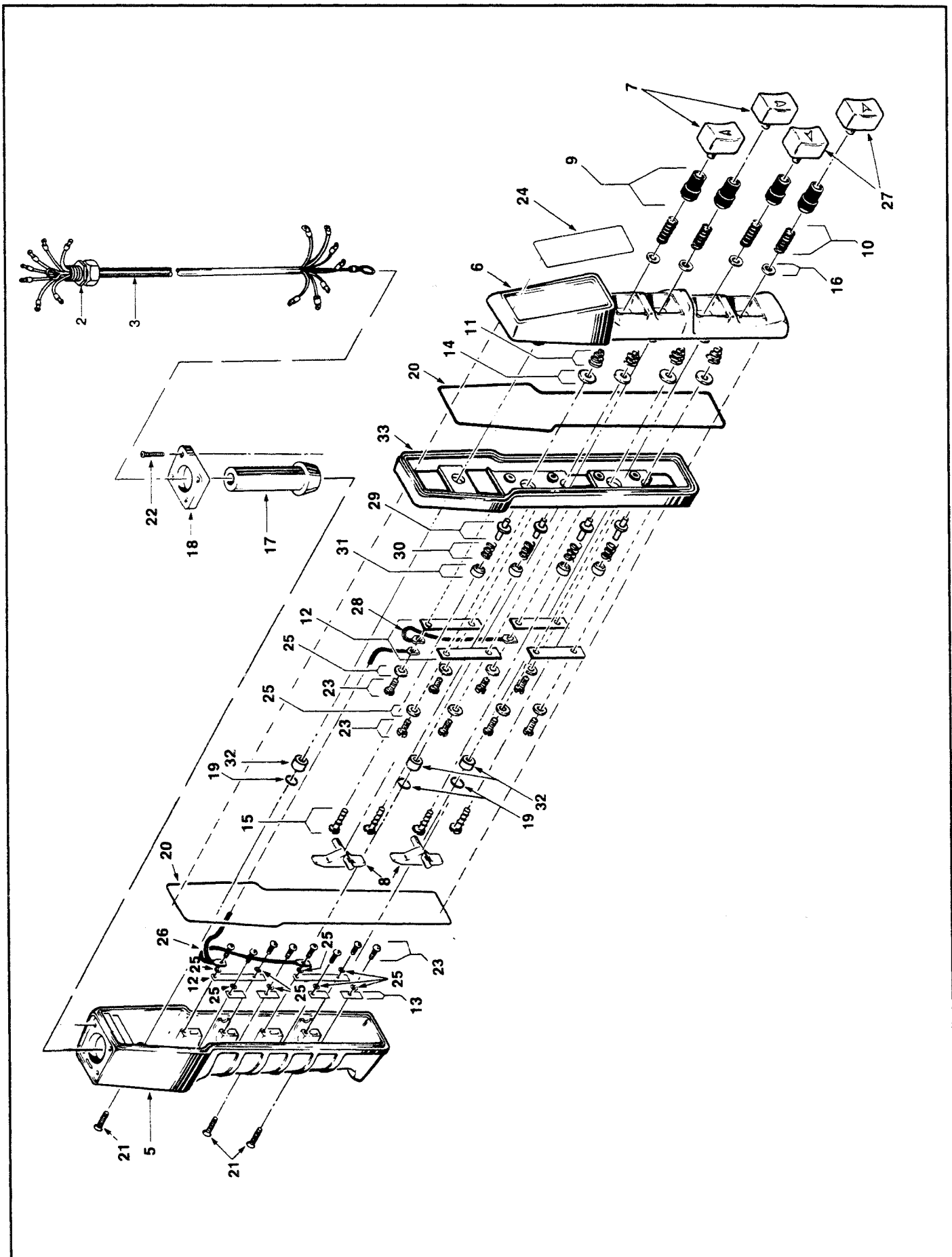

**FIGURE 8-8D. PUSHBUTTON
(TWO SPEED HOIST, SINGLE SPEED TROLLEY; SINGLE SPEED HOIST, TWO SPEED TROLLEY)**

Index No.	Part Name	Part No.
2	Connector	H-7609
3	Push Button Cable Assembly: 16 ft. Drop	
	Special Length Drop (*Equal to P.B. Drop)	PB-309-16 PBS-309-*
4	Push Button Assembly (Consists of Index Nos. 5 thru 34) Two Speed Hoist-Single Speed Trolley	534JG5
	Single Speed Hoist-Two Speed Trolley	534JG6
5	Enclosure	PB-282-4
6	Cover	PB-283
7	Push Button (Hoist)	PB-284-22
8	Interlock (Two-speed, Black)	PB-285-1
9	Boot	PB-286
10	Spring, Compression	PB-287
11	Spring, Conical	PB-288
12	Contact Plate, Common	PB-290
13	Contact Plate	PB-289
14	Washer, Contact	PB-291
15	Screw	H-1852-P

Index No.	Part Name	Part No.
16	Washer, Boot	PB-293
17	Grommet	PB-294-2
18	Cap, Enclosure	PB-295
19	"O" Ring	X-6477-1
20	Seal	H-7851
21	Screw	H-2925
22	Screw	H-2992
23	Screw	H-2993
24	Warning Tag	PB-296
25	Lock Washer	H-4160
26	Jumper	JF-940-111
27	Push Button (Trolley)	PB-284-21
28	Spacer	755J2
29	Spring, Lower	344J5
30	Insulating Bushing	755J1
31	Lower Contact	201J1
32	Bushing	200J16
33	2-Speed Adapter	PB-308
34	Interlock (Single-speed, Red)	PB-285

**FIGURE 8-8D. PUSHBUTTON
(TWO SPEED HOIST, SINGLE SPEED TROLLEY; SINGLE SPEED HOIST, TWO SPEED TROLLEY)**



**FIGURE 8-8E. PUSHBUTTON
(TWO SPEED HOIST, TWO SPEED TROLLEY)**

Index No.	Part Name	Part No.
2	Connector	H-7609
3	Push Button Cable Assembly: 16 ft. Drop	
	Special Length Drop (*Equal to P.B. Drop)	PB-309-16
4	Push Button Assembly (Consists of Index Nos. 5 thru 33)	PB-309-*
		534JG7
5	Enclosure	PB-282-4
6	Cover	PB-283
7	Push Button (Hoist)	PB-284-22
8	Interlock (Two-speed, Black)	PB-285-1
9	Boot	PB-286
10	Spring, Compression	PB-287
11	Spring, Conical	PB-288
12	Contact Plate, Common	PB-290
13	Contact Plate	PB-289
14	Washer, Contact	PB-291
15	Screw	H-1852-P
16	Washer, Boot	PB-293

Index No.	Part Name	Part No.
17	Grommet	PB-294-2
18	Cap, Enclosure	PB-295
19	"O" Ring	X-6477-1
20	Seal	H-7851
21	Screw	H-2925
22	Screw	H-2992
23	Screw	H-2993
24	Warning Tag	PB-296
25	Lock Washer	H-4160
26	Jumper	JF-940-111
27	Push Button (Trolley)	PB-284-21
28	Jumper (2-Speed Common)	JF-940-42
29	Insulating Bushing	755J1
30	Spring, Lower	344J5
31	Lower Contact	201J1
32	Bushing	200J16
33	2-Speed Adapter	PB-308

**FIGURE 8-8E. PUSHBUTTON
(TWO SPEED HOIST, TWO SPEED TROLLEY)**

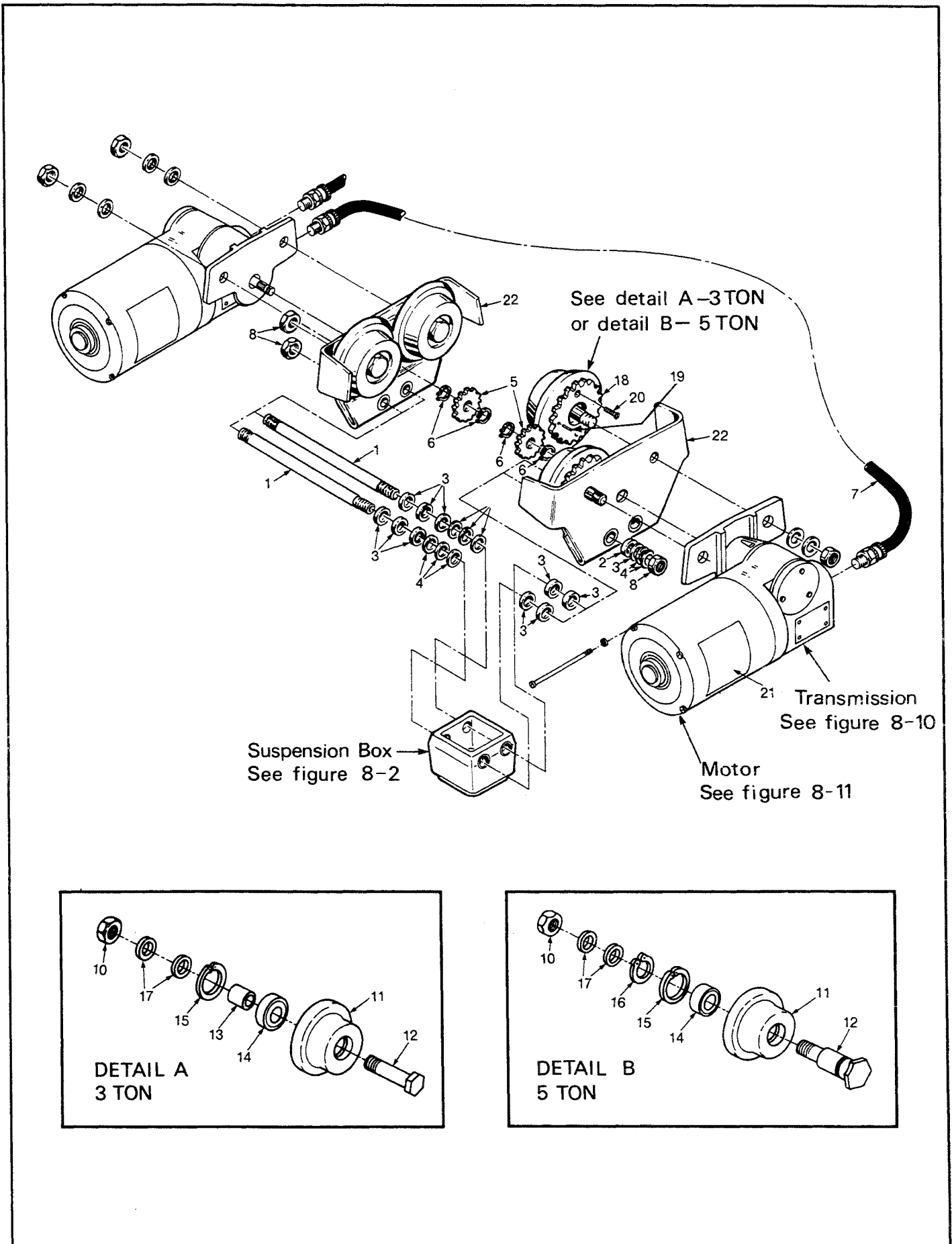
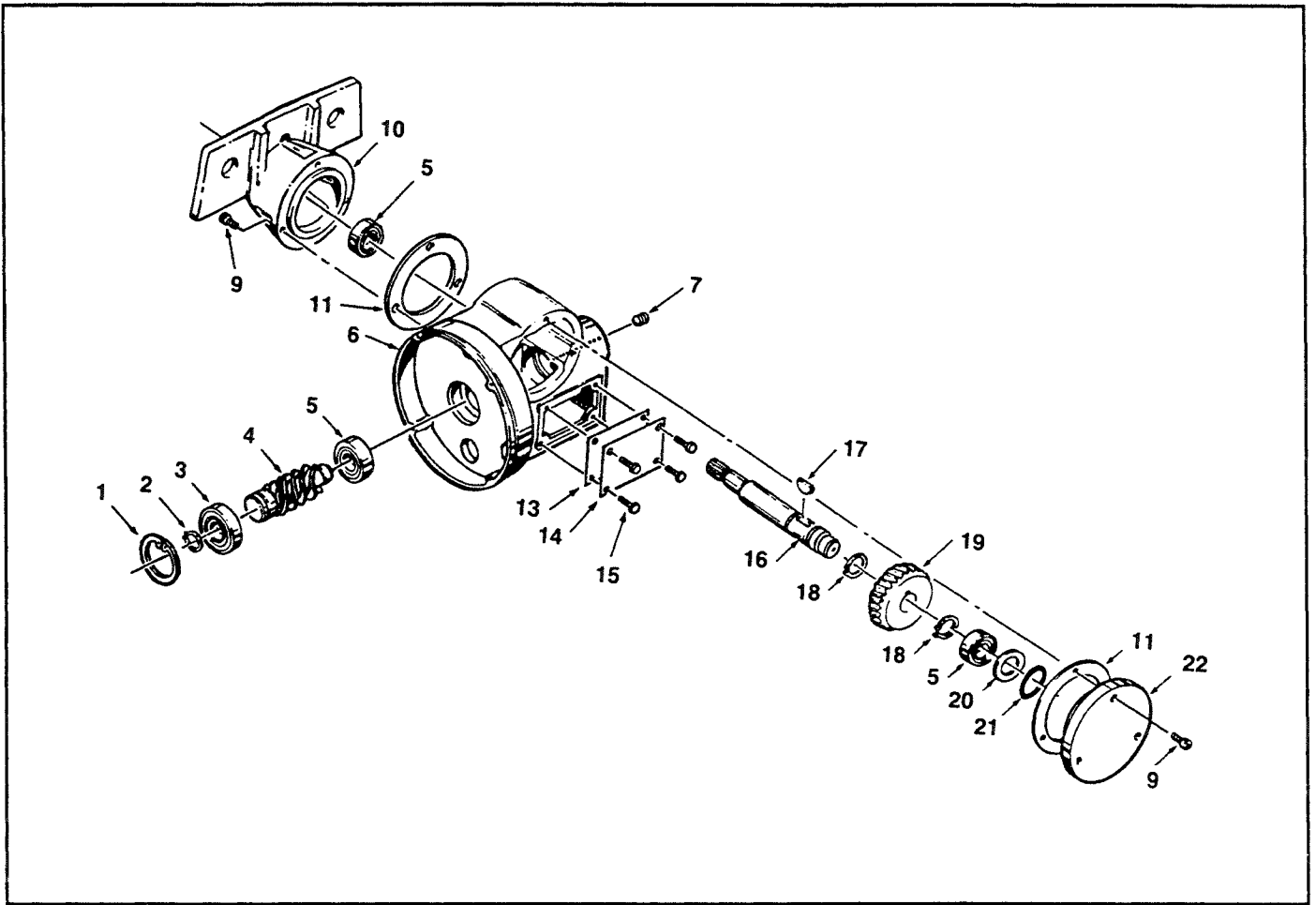

FIGURE 8-9. TROLLEY

Index No.	Part Name	Part No.
1	Load Pin (up to 6" flange width)	103K1
2	Washer (1/8" thick)	H-4211
3	Washer (.135 thick)	H-4209
4	Washer (.075 thick)	H-4210
5	Pinion	420K1
6	Retaining Ring	H-5501
7	Tie Cable Assembly (motor to motor):	
	Single Speed Trolley	955KG6
	Two Speed Trolley	955KG9
8	Nut, Load Pin	H-3945
9	Wheel Assembly (for S-shape I-Beam Only): (Consists of Index No. 10 thru 20)	
	3 Ton:	
	Geared Wheel Assembly	45KG2
	Plain Wheel Assembly	45KG1
	5 Ton:	
	Geared Wheel Assembly	45KG4
	Plain Wheel Assembly	45KG3
10	Nut, Axle:	
	3 Ton	H-3945
	5 Ton	H-3946
11	Wheel (for S-shape I-Beam Only):	
	3 Ton:	
	Geared Wheel (Gear Not Included)	45K1

Index No.	Part Name	Part No.
	Plain Wheel	45K10
	5 Ton:	
	Geared Wheel (Gear Not Included)	45K2
	Plain Wheel	45K20
12	Axle:	
	3 Ton	102K1
	5 Ton	102K2
13	Spacer (3 Ton Only)	200K1
14	Bearing:	
	3 Ton	500K4
	5 Ton	500K5
15	Retaining Ring:	
	3 Ton	H-5528
	5 Ton	H-5530
16	Retaining Ring (5 Ton Only)	H-5529
17	Washer:	
	3 Ton	H-4211
	5 Ton	H-4212
18	Gear	420K2
19	Pin, Spirol	H-5531
20	Screw	H-2165
21	Decal	677J7
22	Sideplate:	
	3 Ton	5KG4
	5 Ton	5KG31

FIGURE 8-9. TROLLEY



Index No.	Part Name	Part No.
1	Retaining Ring	SK2658-6
2	Retaining Ring	H-5549
3	Bearing	JF-504-2
4	Worm:	
	35 FPM	485K21
	75 FPM	485K22
5	Bearing	500K3
6	Gear Housing	39K22
7	Plug	S-25-13
9	Screw	H-2215
10	Adapter Housing:	
	3 Ton	38K60
	5 Ton	38K61

Index No.	Part Name	Part No.
11	Gasket	560K2
13	Gasket	560K3
14	Splice Plate	295K1
15	Screw	H-1009-P
16	Shaft	100K13
17	Woodruff Key	S-23-15
18	Retaining Ring	H-5527
19	Worm Gear:	
	35 FPM	487K4
	75 FPM	487K3
20	Shim Washer	202K1
21	"O" Ring	H-5609
22	End Cap	32K3

FIGURE 8-10. TROLLEY TRANSMISSION

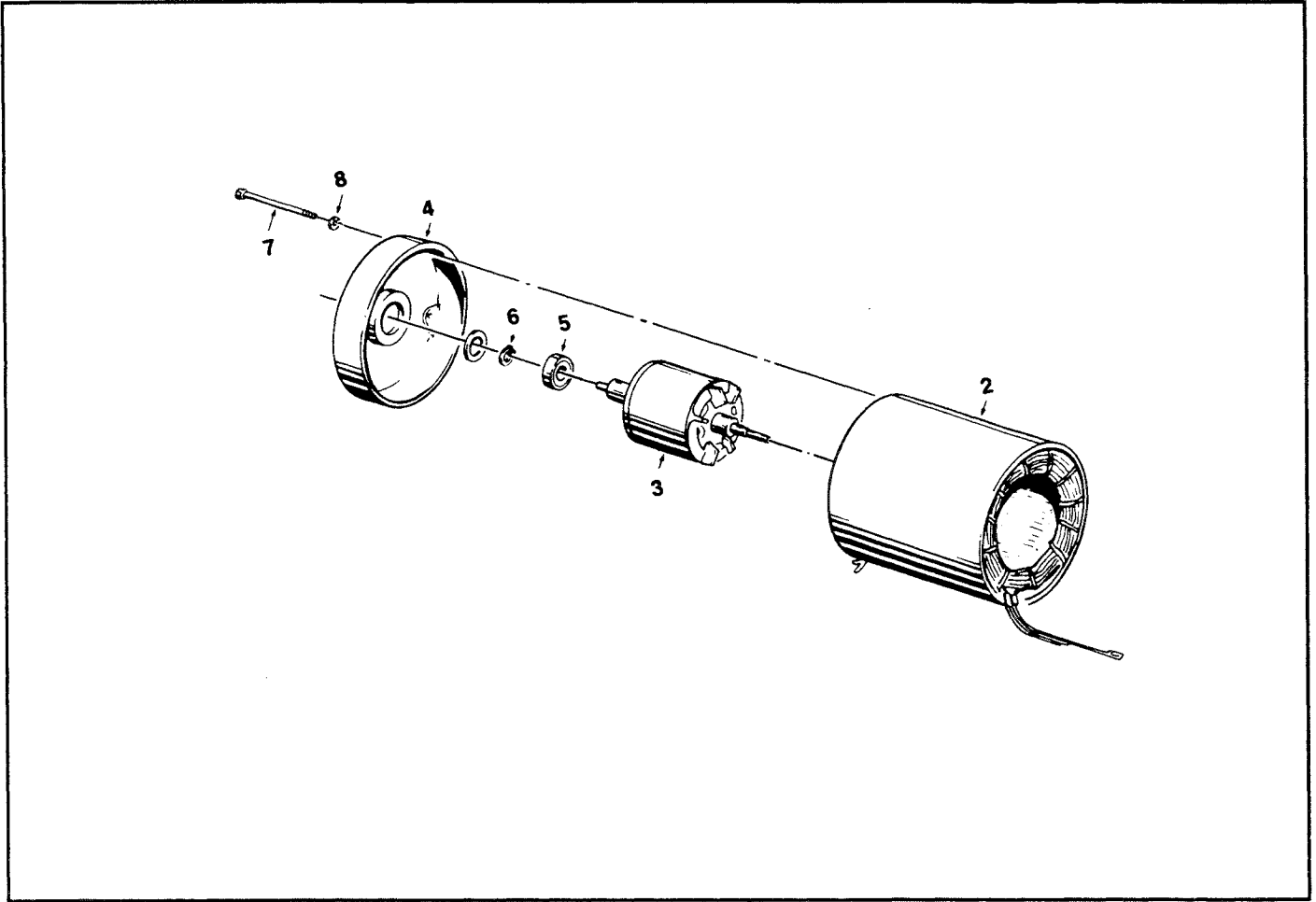

Index No.	Part Name	Part No.
1	Motor Complete:	
	Single Speed:	
	208, 230/460V, 3-PH, 60 Hz, 1/4 HP	JL-863-1M
	208, 230/460V, 3-PH, 60 Hz, 1/2 HP	JL-863-2
	575V, 3-PH, 60 Hz, 1/4 HP	JL-863-5M
	575V, 3-PH, 60 Hz, 1/2 HP	JL-863-6
	Two Speed:	
	208, 230V, 3-PH, 60 Hz, 1/4 HP	JL-873-1M
	208,230V, 3-PH, 60 Hz, 1/2 HP	JL-873-2M
	460V, 3-PH, 60 Hz, 1/4 HP	JL-873-5M
	460V, 3-PH, 60 Hz, 1/2 HP	JL-873-6M
	575V, 3-PH, 60 Hz, 1/4 HP	JL-873-9M
	575V, 3-PH, 60 Hz, 1/2 HP	JL-873-10M

Index No.	Part Name	Part No.
2	Stator (Not Available Separately)	*
3	Rotor & Shaft	*
4	End Shield	*
5	Bearing, Front	*
6	Ring, Retaining	*
7	Screw, Motor Mount	*
8	Lock Washer	*

*For individual motor parts, contact your Duff-Norton Distributor and supply complete motor nameplate data.

FIGURE 8-11. TROLLEY MOTOR

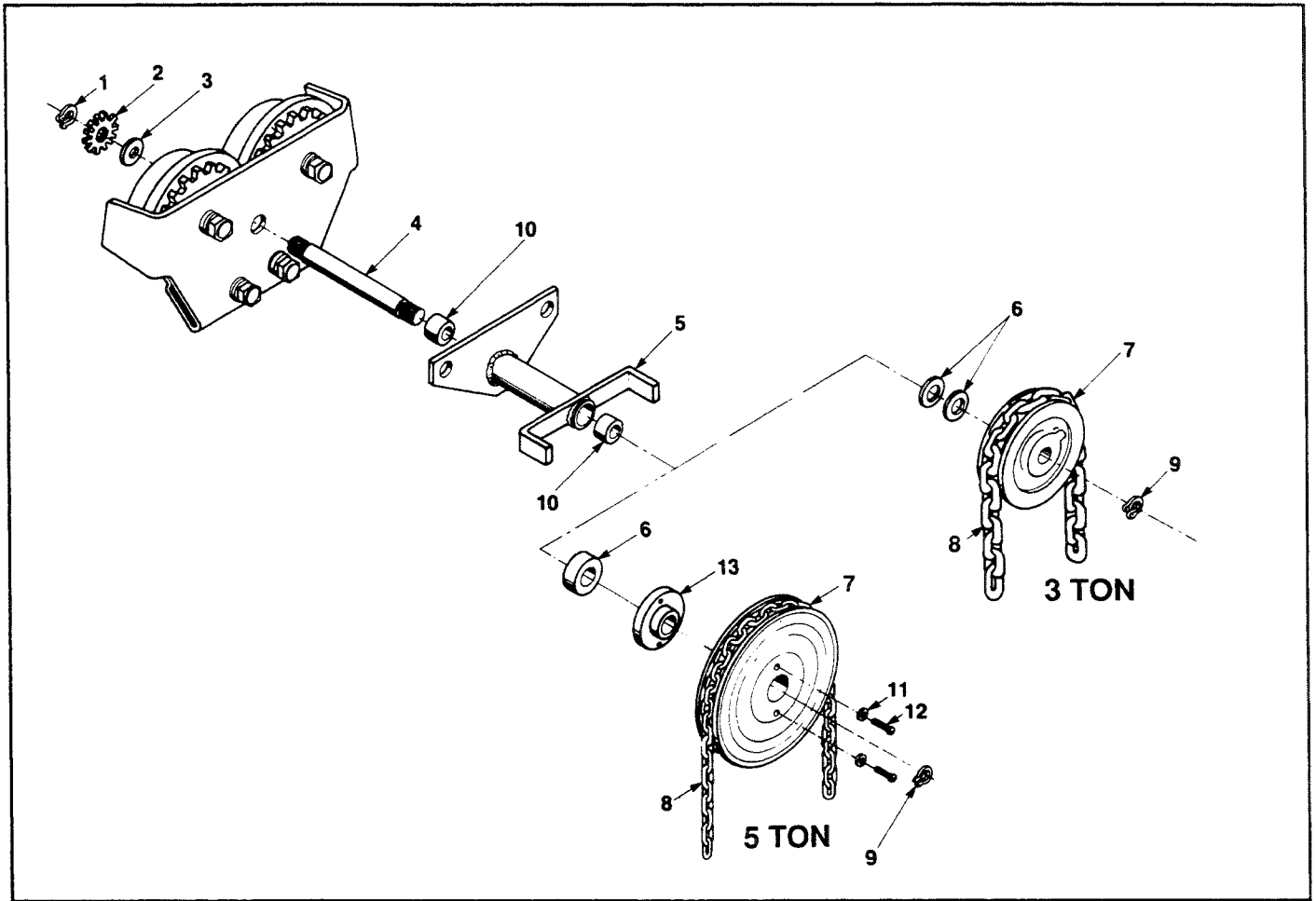

Index No.	Part Name	Part No.
1	Retaining Ring	H-5501
2	Pinion	420K1
3	Spacer Bearing (1/16" Thick)	525K2
4	Gear Shaft	100K14-2
5	Sleeve and Adapter Assembly:	
	3 Ton	51KG1-3
	5 Ton	51KG2-3
6	Spacer Bearing (1/8" Thick)	525K1

Index No.	Part Name	Part No.
7	Hand Chain Wheel:	
	3 Ton	33K23
	5 Ton	33K13
8	Hand Chain (specify length)	53A
9	Retaining Ring	H-5527
10	Sleeve Bushing	530K6
11	Washer	H-4138
12	Bolt	H-2304
13	Hub Adapter	51K4

FIGURE 8-12. GEARED TROLLEY

SECTION IX DO'S AND DO NOT'S

Electric and Air-powered Hoists

The following warnings and operating practices have been taken from American National (Safety) Standard ANSI B30.16 and are intended to avoid unsafe hoisting practices which might lead to personal injury or property damage.

These recommendations apply to all electric and air-powered hoists for vertical lifting service involving material handling of freely suspended unguided loads.

WARNING: TO AVOID INJURY

1. DO read ANSI B30.16 Safety Standard for Overhead Hoists and Hoist Manufacturer's Operating and Maintenance Instructions.
2. DO be familiar with hoist operating controls, procedures and warnings.
3. DO make sure hook travel is in the same direction as shown on controls.
4. DO make sure hoist limit switches function properly.
5. DO maintain firm footing when operating hoist.
6. DO make sure that load slings or other approved sling attachments are properly sized and seated in the hook saddle.
7. DO make sure that the hook latch, if used, is closed and not supporting any part of the load.
8. DO make sure that load is free to move and will clear all obstructions.
9. DO take up slack carefully, check load balance, lift a few inches and check load holding action before continuing.
10. DO avoid swinging of load or load hook.
11. DO make sure that all persons stay clear of the suspended load.
12. DO warn personnel of an approaching load.
13. DO protect wire rope and load chain from weld spatter or other damaging contaminants.
14. DO promptly report any malfunction, unusual performance or damage of the hoist.
15. DO inspect hoist regularly, replace damaged or worn parts and keep appropriate records of maintenance.
16. DO use the hoist manufacturer's recommended parts when repairing a hoist.
17. DO use hook latches wherever possible.
18. DO apply lubricant to the wire rope or load chain as recommended by the hoist manufacturer.
19. DO NOT lift more than rated load.
20. DO NOT use the hoist load limiting device to measure the load.
21. DO NOT use damaged hoist or hoist that is not working correctly.
22. DO NOT use the hoist with twisted, kinked, damaged or worn wire rope or chain.
23. DO NOT lift a load unless wire rope is properly seated in its groove(s) or unless chain is properly seated in chain wheel(s) or sprocket(s).
24. DO NOT use load rope or load chain as a sling or wrap rope or chain around the load.
25. DO NOT lift a load if any binding prevents equal loading on all supporting ropes or chains.
26. DO NOT apply the load to the tip of the hook.
27. DO NOT operate unless load is centered under hoist.
28. DO NOT allow your attention to be diverted from operating the hoist.
29. DO NOT operate the hoist beyond limits of load rope or load chain travel.
30. DO NOT use limit switches as routine operating stops unless recommended. They are emergency devices only.
31. DO NOT use hoist to lift, support or transport people.
32. DO NOT lift loads over people.
33. DO NOT leave a suspended load unattended unless specific precautions have been taken.
34. DO NOT allow sharp contact between two hoists or between hoist and obstructions.
35. DO NOT allow the rope, chain or hook to be used as a ground for welding.
36. DO NOT allow the rope, chain or hook to be touched by a live welding electrode.
37. DO NOT remove or obscure the warnings on the hoist.
38. DO NOT adjust or repair a hoist unless qualified to perform hoist maintenance.
39. DO NOT attempt to lengthen the load rope or chain or repair damaged load rope or chain.

COFFING[®]

HOISTS

WARRANTY

Every hoist is thoroughly inspected and tested prior to shipment from the factory. Should any problem develop, return the complete hoist prepaid to your nearest Coffing Hoists Authorized Warranty Repair Station. If inspection reveals that the problem is caused by defective workmanship or material, repairs will be made without charge and the hoist will be returned, transportation prepaid. This warranty does not apply where: **(1)** deterioration is caused by normal wear, abuse, improper or inadequate power supply, eccentric or side loading, overloading, chemical or abrasive actions, improper maintenance, or excessive heat; **(2)** problems resulted from repairs,

modifications, or alterations made by persons other than factory or Coffing Authorized Warranty Repair Stations personnel; **(3)** the hoist has been abused or damaged as a result of an accident; **(4)** repair parts or accessories other than those supplied by Coffing Hoists are used on the hoist. Equipment and accessories not of the seller's manufacture are warranted by the manufacturer.

Except as stated herein, Coffing Hoists makes no other warranties, express or implied, including warranties or merchantability and fitness for a particular purpose.

⚠ WARNING

Overloading and Improper Use Can Result In Injury

To Avoid Injury:

- Do not exceed working load limit, load rating, or capacity.
- Do not use to lift people or loads over people.
- Use only alloy chain and attachments for overhead lifting.
- Read and follow all instructions.

Coffing Hoists • Country Club Road • P.O. Box 779 • Wadesboro, NC 28170 USA
Customer Service: Tel. (800) 477-5003 (704) 694-2156 • FAX (800) 374-6853 (704) 694-6829