

Drawing number **05 438 05 13 0**
 Stromlaufplan

Control / Steuerung	SH5	
Hoist Motor / Hubmotor	12/2H71	
Type / Ausführung	A (control with transformer + main contactor)	
Overload Device / Lastwächter	SLE21 / SMC21 SLE22 / SMC22	
Voltage / Spannung	440-480V, 575-600V / 110/120V 60Hz	
	380-415V / 110/120V 50Hz	
Fuses / Sicherungen	F41-43	6A Class CC
	F101-102	1A Class CC
Fuses / Sicherungen by customer / bauseits	main fuse	35A Class J

Document Dokument	Sheet Blatt
BILL OF MATERIALS GERÄTELISTE	1 (2)
POWER SUPPLY STROMVERSORGUNG	1 (9)
HOIST HUBWERK	2 (9)
TROLLEY FAHRWERK	5 (9)
CONTROL PENDANT STEUERGERÄT	6 (9)
TERMINAL DIAGRAM X16 KLEMMENPLAN X16	7 (9)
LOCATION DIAGRAM A16 AUFBAUPLAN A16	8 (9)
CABEL DIAGRAM KABELPLAN	9 (9)

Drawing number

05 438 05 13 0

Stromlaufplan

BILL OF MATERIALS

Lokcat. Ort	Refer. Referenz	Qty. Anzahl	Spezifikation Typ	Discription Benennung	Fabricate Hersteller	Item Code Sach-Nr.
+A16	-A275*	1	SLE21 110/120V	OVERLOAD DEVICE	STAHL	579 510 0
		1	SMC21 110/120V	LASTWÄCHTER	STAHL	582 114 0
		1	SLE22 110/120V		STAHL	579 573 0
		1	SMC22 110/120V		STAHL	582 120 0
+A16	-F41-F43	3	USBCC1	FUSE HOLDER SICHERUNGSTRENNER	FERRAZ	510 078 0
		3	ATDR6 10x38 6A	FUSE LINK SCHMELZEINSATZ	FERRAZ	510 083 0
+A16	-F101-F102	2	USBCC1	FUSE HOLDER SICHERUNGSTRENNER	FERRAZ	510 078 0
		2	ATDR1 10x38 1A	FUSE LINK SCHMELZEINSATZ	FERRAZ	510 466 0
+A16	-G21	1	20/017.100.2 2A	RECTIFIER GLEICHRICHTER	MAYR	04 430 04 88 0
+A16	-K10	1	LC1-D25 G7	CONTACTOR SCHÜTZ	TELEMECANIQUE	582 043 0
+A16	-K23-K24	2	LC1-D25 G7	CONTACTOR SCHÜTZ	TELEMECANIQUE	582 043 0
		2	LAD-N11G	AUXILIARY CONTACT BLOCK HILFSSCHALTERBLOCK	TELEMECANIQUE	582 069 0
+A16	-K25	1	LC1-D258 G7	CONTACTOR SCHÜTZ	TELEMECANIQUE	582 047 0
+A16	-K29	1	LC1-D09 G7	CONTACTOR SCHÜTZ	TELEMECANIQUE	582 041 0
+A16	-K41-K42	1	LC2-K09 G7	CONTACTOR SCHÜTZ	TELEMECANIQUE	579 472 0
+A16	-K45	1	LC1-K09008 G7	CONTACTOR SCHÜTZ	TELEMECANIQUE	579 473 0
+A16	-Q29	1	GV2 RT10	CIRCUIT BREAKER LEISTUNGSSCHALTER	TELEMECANIQUE	579 507 0
		1	GV AN20	AUXILIARY CONTACT BLOCK HILFSSCHALTERBLOCK	TELEMECANIQUE	579 505 0
+A16	-S220	1	GE-S125.04	GEAR-TYPE LIMIT SWITCH GETRIEBEENDSCHALTER	STROMAG	580 005 0
+A16	-S260/-S261	2	E 215-16-11B	PUSH BUTTON DRUCKTASTER	ABB	578 553 0
+A16	-T100*	1	RSTN 100-UL-CSA 440-460-480V / 115V	TRANSFORMER TRANSFORMATOR	RIEDEL	579 568 0
		1	RSTN 100-UL-CSA 550-575-600V / 115V	TRANSFORMER TRANSFORMATOR	RIEDEL	579 569 0
		1	RSTN 100-UL-CSA 380-400-415V / 115V	TRANSFORMER TRANSFORMATOR	RIEDEL	579 583 0
		1	WPE16	PE-TERMINAL SCHUTZLEITERKLEMME	WEIDMUELLER	519 518 0
+A16	-X16	3	WDU16	TERMINAL KLEMME	WEIDMUELLER	519 513 0
		2	WDU10	TERMINAL KLEMME	WEIDMUELLER	519 512 0
		1	WPE10	PE-TERMINAL SCHUTZLEITERKLEMME	WEIDMUELLER	519 517 0
		4	PPE2.5/4	PE-TERMINAL SCHUTZLEITERKLEMME	WEIDMUELLER	519 521 0
		18	PDU2.5/4	TERMINAL KLEMME	WEIDMUELLER	519 520 0

* to note accomplishment! / Ausführung beachten!

Date / Datum	Dept. / Abteilung	Designer / Bearbeiter	Page / Seite
09.07.2014	TEPE	Huhndorf	1/2

Drawing number

05 438 05 13 0

Stromlaufplan

BILL OF MATERIALS

Lokcat. Ort	Refer. Referenz	Qty. Anzahl	Spezifikation Typ	Discription Benennung	Fabricate Hersteller	Item Code Sach-Nr.
+TR	-B275	1		LOAD SENSOR LASTSENSOR		
+TR	-M21	1		HOIST MOTOR HUBMOTOR		
+TR	-M41	1		TROLLEY MOTOR KATZFAHRMOTOR		
+TR	-S228	1		BLOCK OPERATED UPPER LIMT SWITCH ENDSCHALTER (US)		
+TR	-S420	1		TROLLEY LIMIT SWITCH KATZFAHRENSCHALTER		

Date / Datum	Dept. / Abteilung	Designer / Bearbeiter	Page / Seite
09.07.2014	TEPE	Huhndorf	2/2

power supply
Netzanschluss

control transformer
Steuertransformator

emergency hoist limit switch
Nothubendschalter

crane switch
Kranschalter

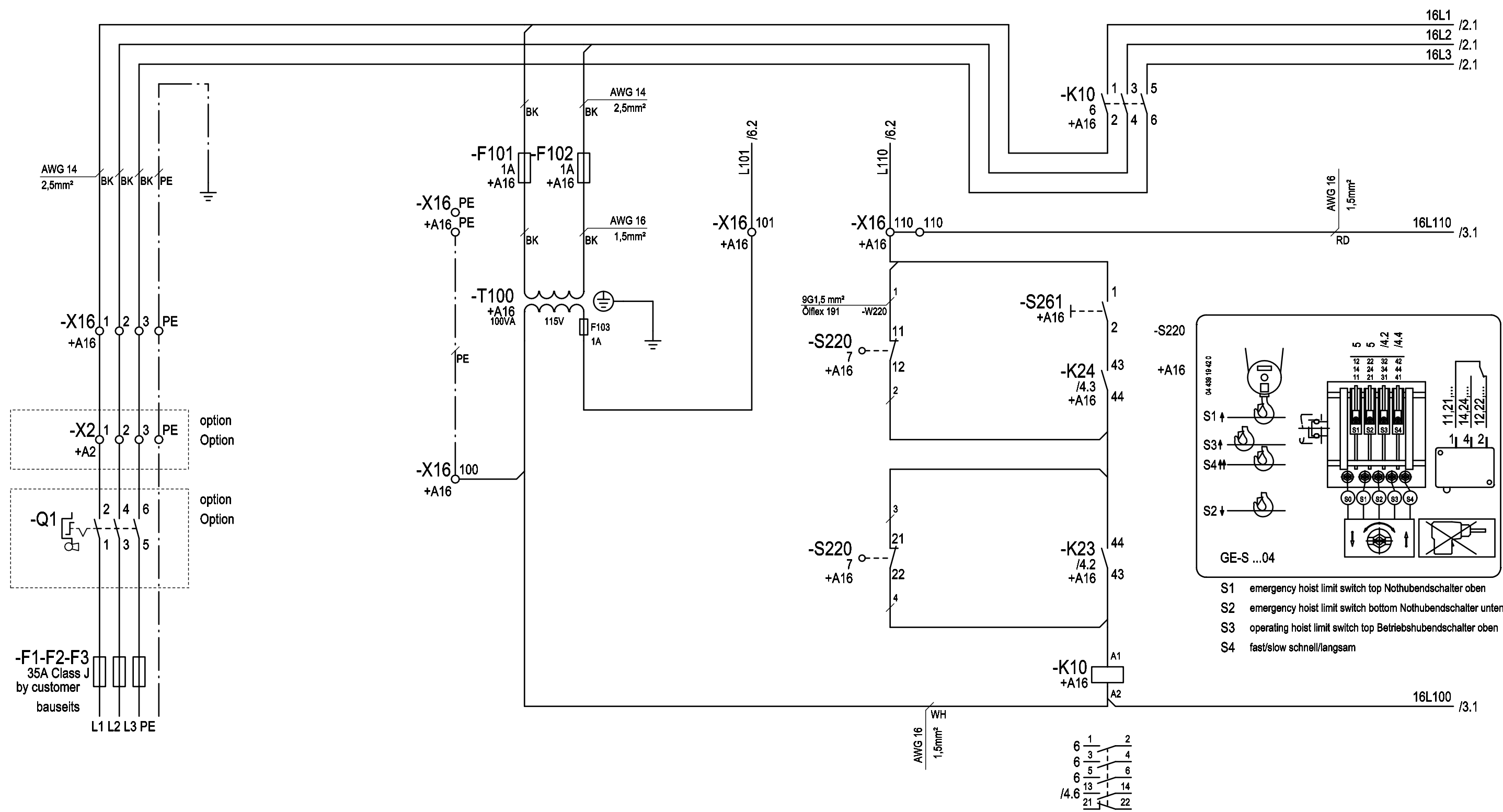

16L1 /2.1
16L2 /2.1
16L3 /2.1

16L110 /3.1

16L100 /3.1

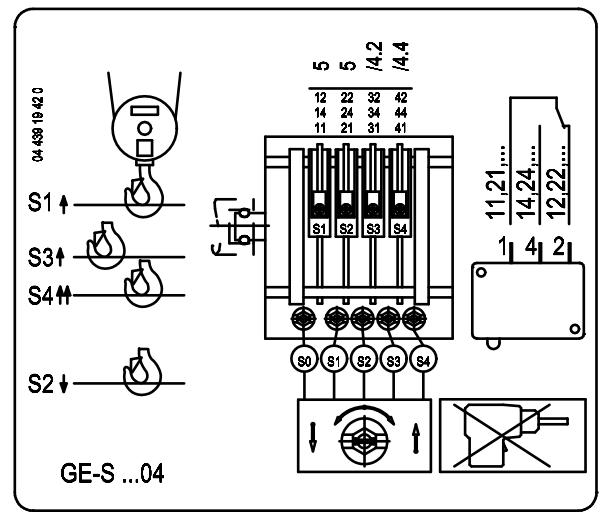

- S1 emergency hoist limit switch top Nothubendschalter oben
- S2 emergency hoist limit switch bottom Nothubendschalter unten
- S3 operating hoist limit switch top Betriebshubendschalter oben
- S4 fast/slow schnell/langsam

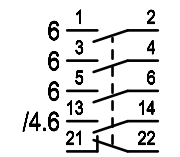

Changes	Date	Name		Date	Name
	09.07.14	Huhnd.	Editor	03.07.09	Huhnd.
			Proved	03.07.09	Nic.
			Release	03.07.09	Huhnd.
Rev.			Plot	09.07.2014	

Rep. by	Rep. for	Origin
---------	----------	--------

Copyright according to DIN ISO 16016	circuit diagram SH5 H71 type A SLE/SMC power supply
Order No.	Serial No.

=	
+	
05 438 05 13 0	Page: 1 of: 9

hoist motor
Hubmotor

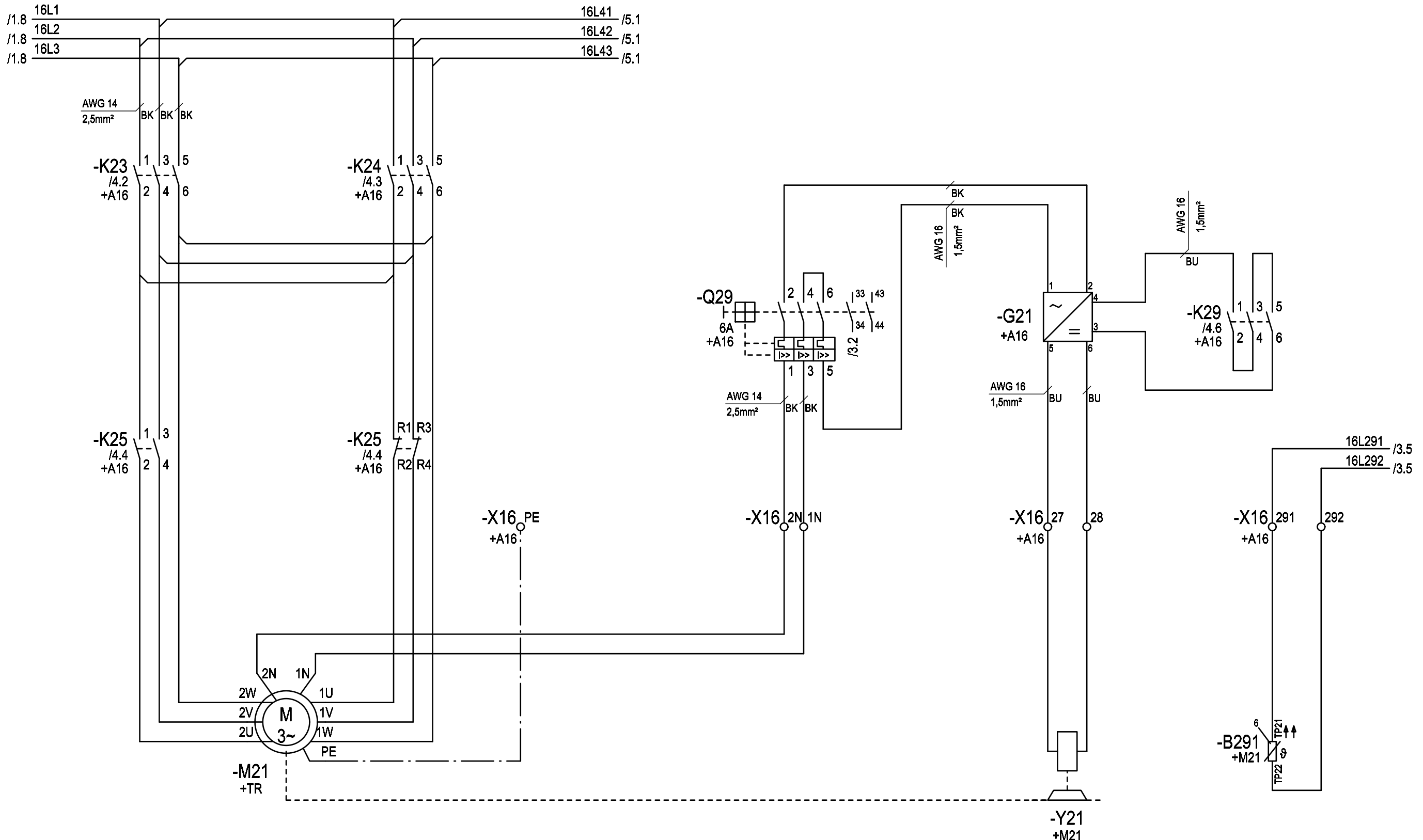

Changes	Date	Name	Date	Name
	09.07.14	Huhnd.	03.07.09	Huhnd.
			03.07.09	Nic.
			03.07.09	Huhnd.
Rev.		Plot	09.07.2014	Rep. by

Rep. for	Origin
----------	--------

Copyright according to DIN ISO 16016	circuit diagram SH5 H71 type A SLE/SMC hoisting
Order No.	Serial No.

=	
+	
05 438 05 13 0	Page: 2 of: 9

hoisting
heben

lowering
senken

fast
schnell

temperature / load monitoring
Temperatur- / Lastüberwachung

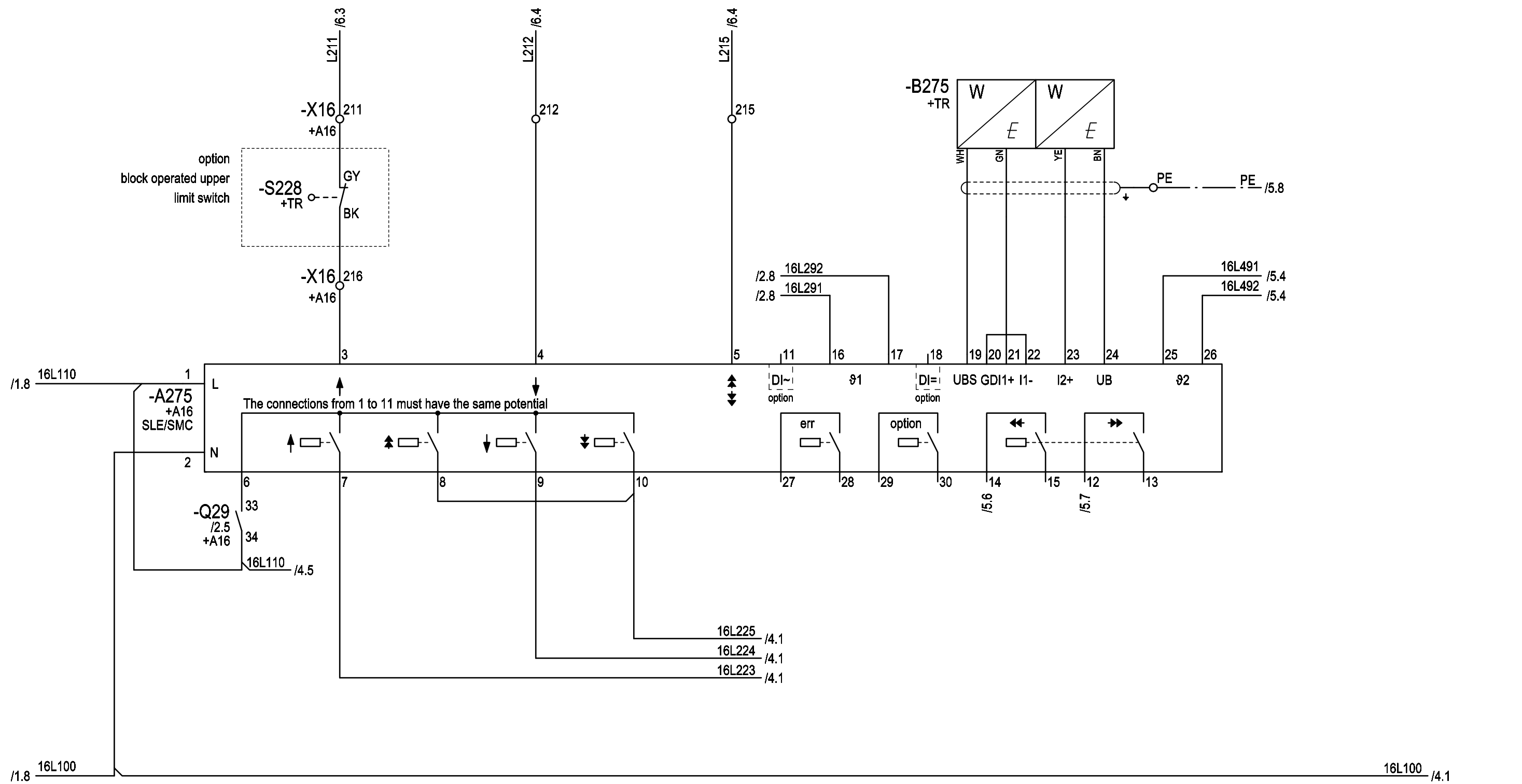

Changes	Date	Name	Date	Name
	09.07.14	Huhnd.	03.07.09	Huhnd.
			03.07.09	Nic.
			03.07.09	Huhnd.
Rev.			09.07.2014	

Rep. by	Rep. for	Origin
---------	----------	--------

Copyright according to DIN ISO 16016	circuit diagram SH5 H71 type A SLE/SMC hoisting
Order No.	Serial No.

=	
+	
05 438 05 13 0	Page: 3 of: 9

hoisting
heben

lowering
senken

fast
schnell

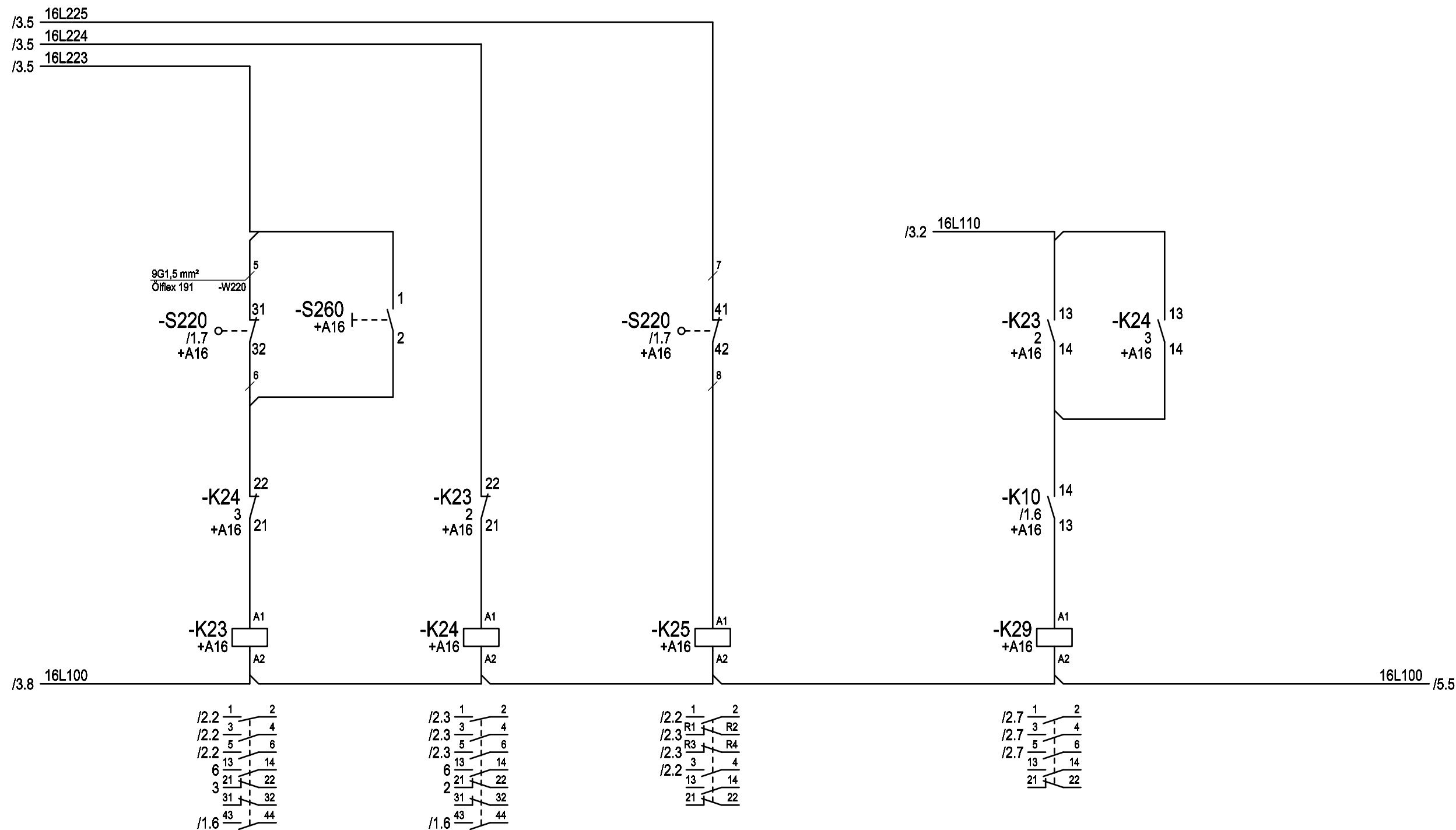

Rev.	Changes	Date	Name	Date	Name
		09.07.14	Huhnd.	03.07.09	Huhnd.
				03.07.09	Nic.
				03.07.09	Huhnd.
				09.07.2014	

Rep. by	Rep. for	Origin
---------	----------	--------

Copyright according to DIN ISO 16016	circuit diagram SH5 H71 type A SLE/SMC hoisting
Order No.	Serial No.

=	
+	
05 438 05 13 0	Page: 4 of: 9

cross travel motor
Katzfahrmotor

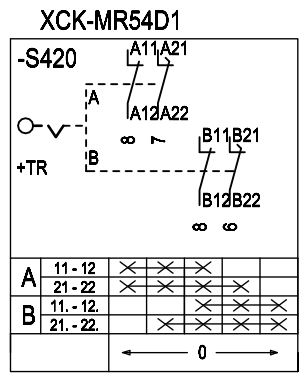
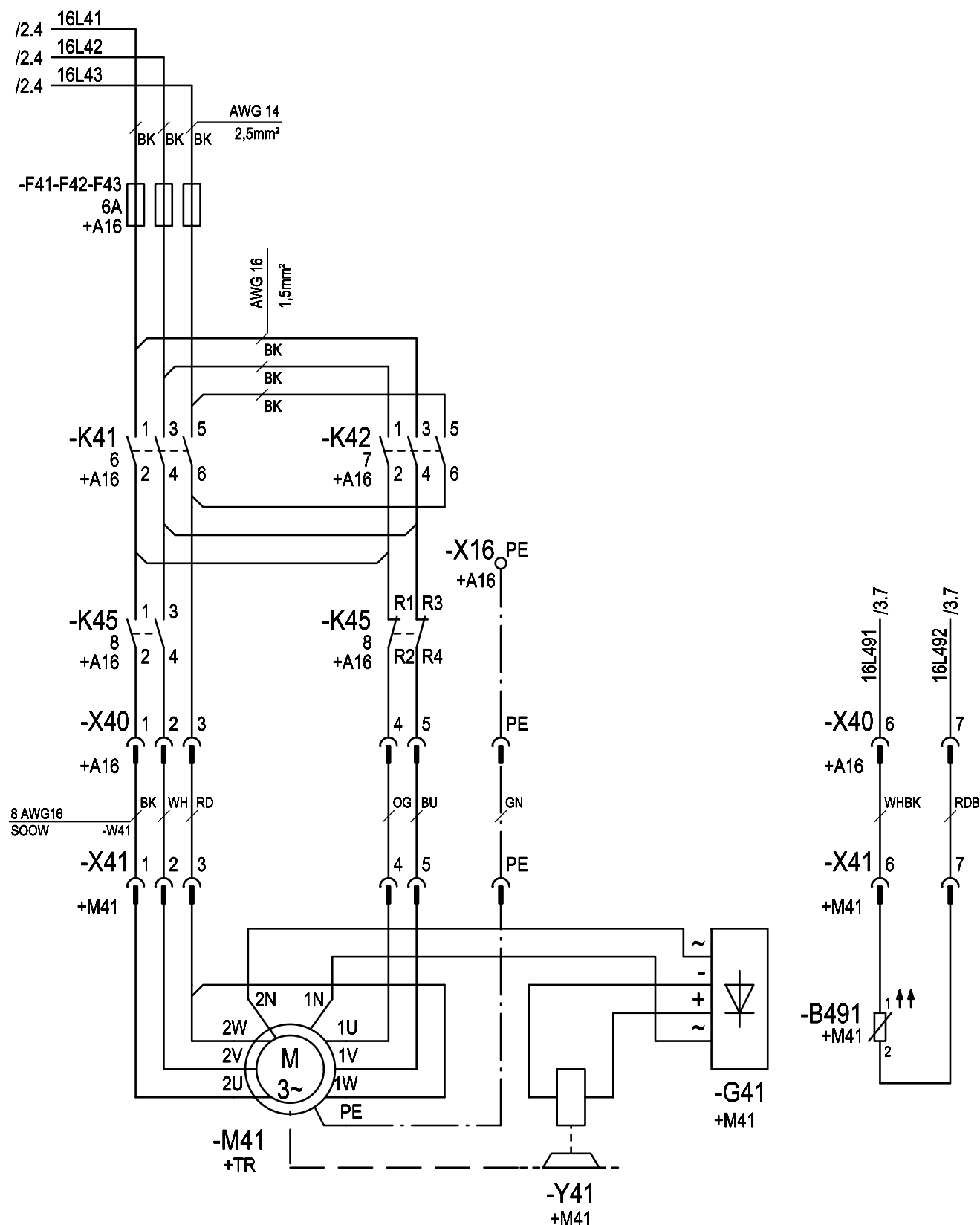

Attention!
with double-rail crab: change contact A21-A22 and B21-B22
Bei Obergurttfahrwerken: Kontakte A21-A22 und B21-B22 tauschen

left links
right rechts
fast schnell

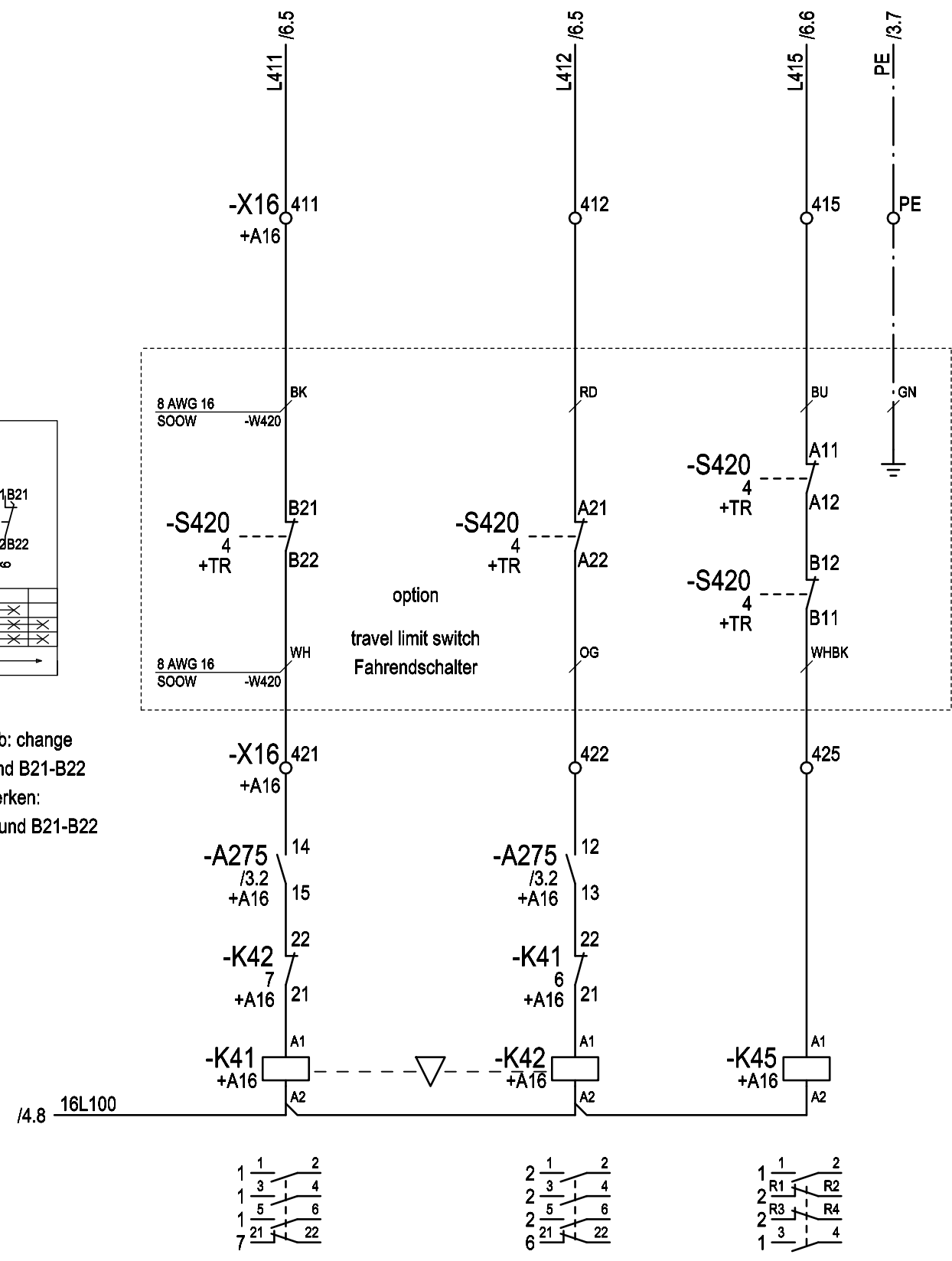

Changes	Date	Name	Date	Name
	09.07.14	Huhnd.	03.07.09	Huhnd.
			03.07.09	Nic.
			03.07.09	Huhnd.

Rep. by	Origin
---------	--------

Copyright according to DIN ISO 16016	circuit diagram SH5 H71 type A SLE/SMC trolley
Order No.	Serial No.

=	
+	
05 438 05 13 0	Page: 5 of: 9

option

hoisting gear
Hubwerk

trolley traveling gear
Katzfahrwerk

emergency stop
Not-Halt

hoisting
heben

lowering
senken

fast
schnell

left
links

right
rechts

fast
schnell

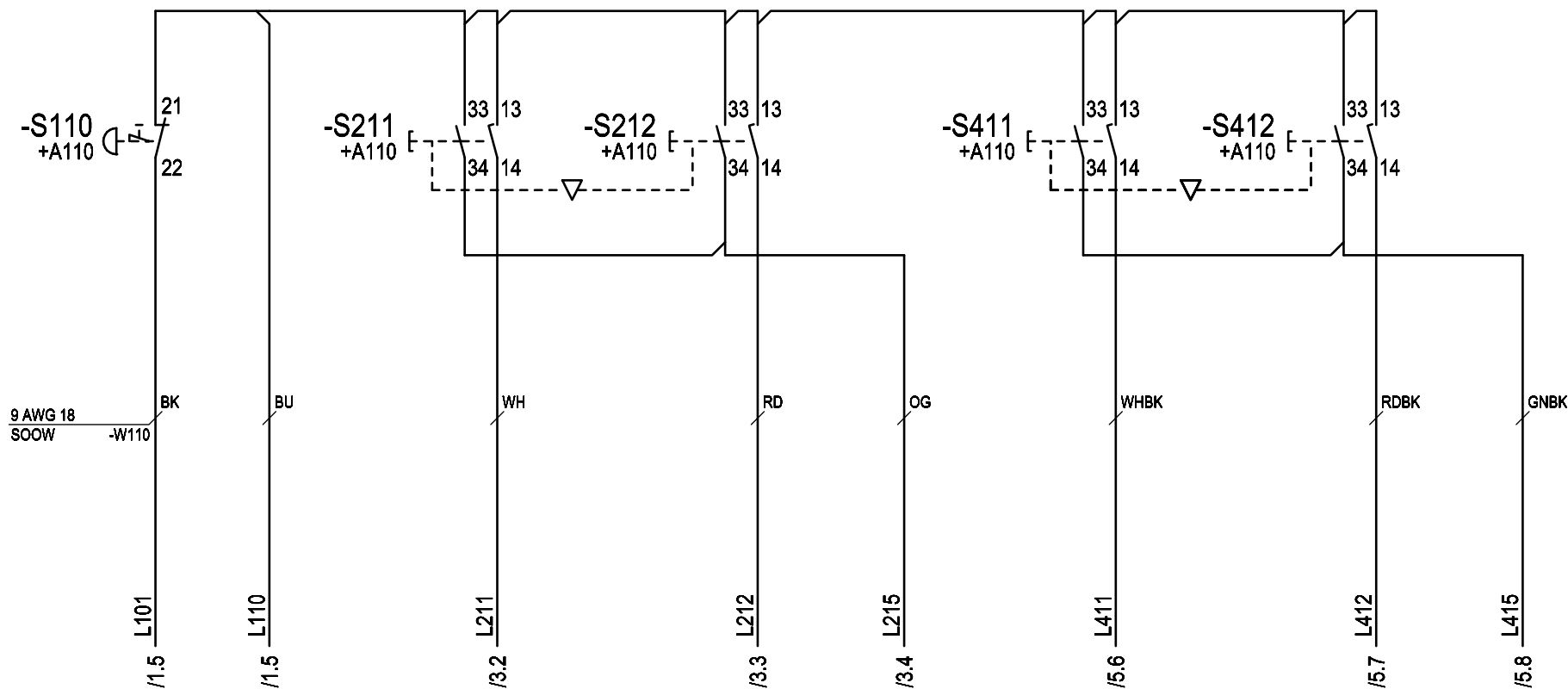

Rev.	Changes	Date	Name	Date	Name
		09.07.14	Huhnd.	03.07.09	Huhnd.
				03.07.09	Nic.
				03.07.09	Huhnd.
				09.07.2014	

Rep. by	Rep. for	Origin
---------	----------	--------

Copyright according to DIN ISO 16016	circuit diagram SH5 H71 type A SLE/SMC control pendant
Order No.	Serial No.

=	
+	
05 438 05 13 0	Page: 6 of: 9

GK SH5

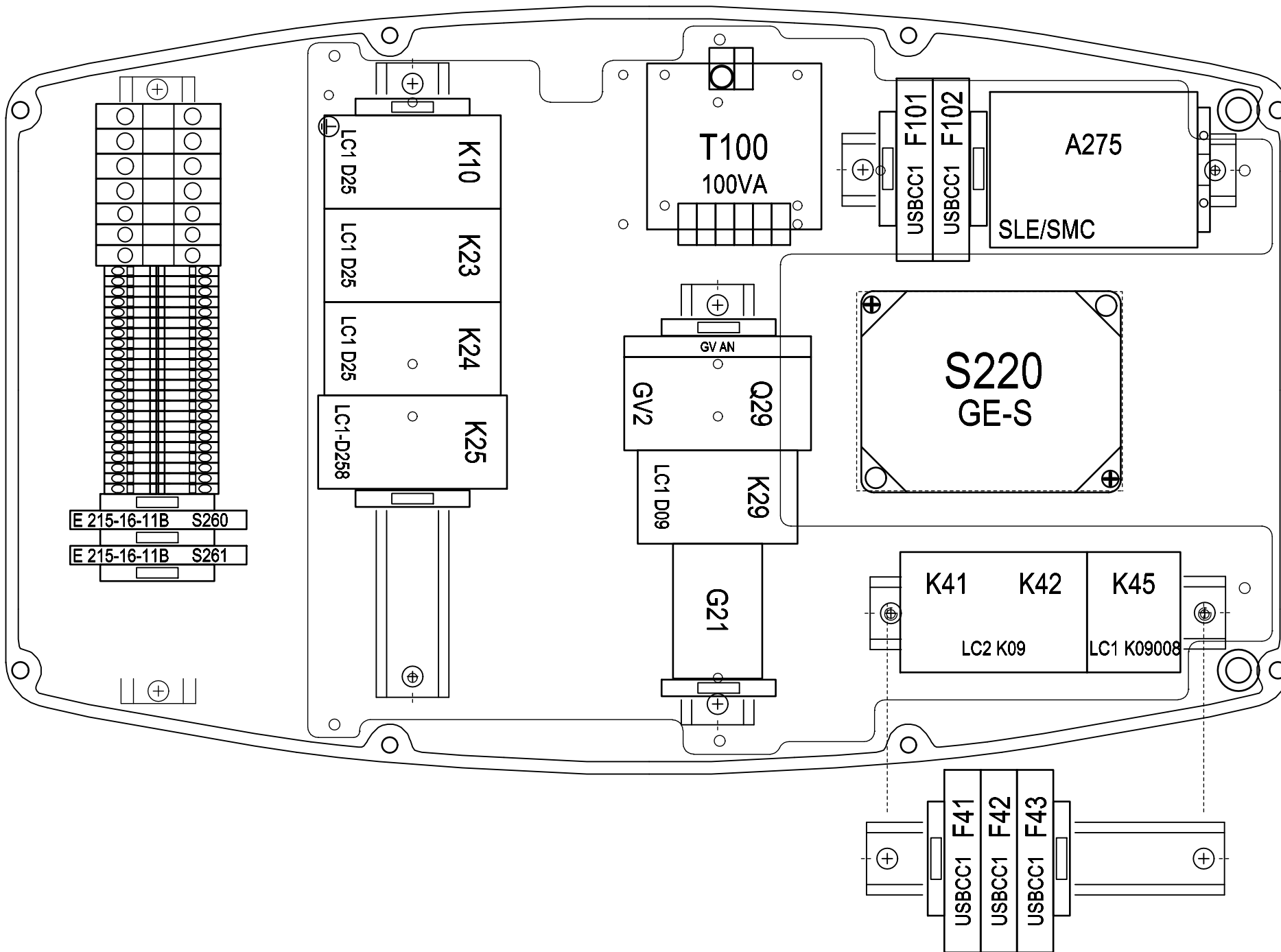

Changes	Date	Name	Date	Name
	09.07.14	Huhnd.	03.07.09	Huhnd.
			03.07.09	Nic.
			03.07.09	Huhnd.
Rev.			09.07.2014	

Rep. by	Rep. for	Origin
---------	----------	--------

Copyright according to DIN ISO 16016

location diagram
SH5 H71 type A SLE/SMC
+A16

Order No. Serial No.

=

+

05 438 05 13 0

Page: 8
of: 9

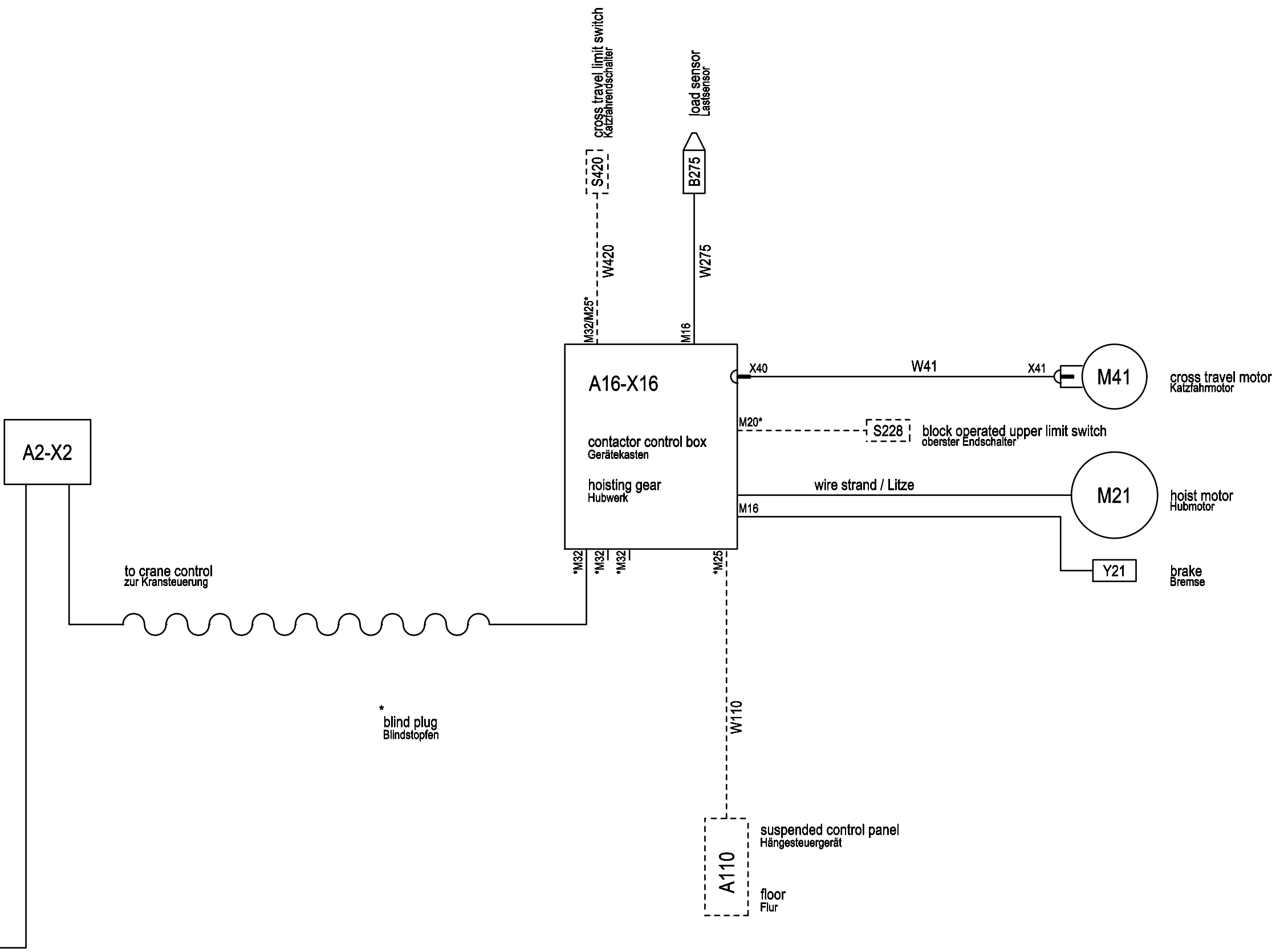

Changes			Date	Name	Date	Name	Copyright according to DIN ISO 16016	cable diagram SH5 H71 type A SLE/SMC	=
			09.07.14	Huhnd.	03.07.09	Huhnd.			
					03.07.09	Nic.			
					03.07.09	Huhnd.			
Rev.			Plot	09.07.2014	Rep. by	Rep. for	Origin	Order No.	Serial No.
								05 438 05 13 0	Page: 9 of: 9