

Drawing number**05 438 33 13 0**

Stromlaufplan

Control / Steuerung	SH5	
Hoist Motor / Hubmotor	12/2H71	
Type / Ausführung	A (control with transformer + main contactor)	
Overload Device / Lastwächter	SLE3	
Voltage / Spannung	440-480V, 575-600V / 110/120V 60Hz	
Fuses / Sicherungen	F41-43	6A Class CC
	F101-102	1A Class CC
Fuses / Sicherungen by customer / bauseits	main fuse	35A Class J

Document Dokument	Sheet Blatt
BILL OF MATERIALS GERÄTELISTE	1 (2)
POWER SUPPLY STROMVERSORGUNG	1 (9)
HOIST HUBWERK	2 (9)
TROLLEY FAHRWERK	5 (9)
CONTROL PENDANT STEUERGERÄT	6 (9)
TERMINAL DIAGRAM X16 KLEMMENPLAN X16	7 (9)
LOCATION DIAGRAM A16 AUFBAUPLAN A16	8 (9)
CABEL DIAGRAM KABELPLAN	9 (9)

Date / Datum	Dept. / Abteilung	Designer / Bearbeiter	Page / Seite
07.08.2018	G-Plattform	Schnell	1/1

Drawing number

05 438 33 13 0

Stromlaufplan

BILL OF MATERIALS

Lokcat. Ort	Refer. Referenz	Qty. Anzahl	Spezifikation Typ	Discription Benennung	Fabricate Hersteller	Item Code Sach-Nr.
+A16	-A275	1	SLE3 110/120V	OVERLOAD DEVICE LASTWÄCHTER		579 770 0
+A16	-F41-F43	3	USBCC1	FUSE HOLDER SICHERUNGSTRENNER	FERRAZ	510 078 0
		3	ATDR6 10x38 6A	FUSE LINK SCHMELZEINSATZ	FERRAZ	510 083 0
+A16	-F101-F102	2	USBCC1	FUSE HOLDER SICHERUNGSTRENNER	FERRAZ	510 078 0
		2	ATDR1 10x38 1A	FUSE LINK SCHMELZEINSATZ	FERRAZ	510 466 0
+A16	-G21	1	20/017.100.2 2A	RECTIFIER GLEICHRICHTER	MAYR	04 430 04 88 0
+A16	-K10	1	LC1-D25 G7	CONTACTOR SCHÜTZ	SCHNEIDER	582 043 0
+A16	-K23-K24	2	LC1-D25 G7	CONTACTOR SCHÜTZ	SCHNEIDER	582 043 0
		2	LAD-N11G	AUXILIARY CONTACT BLOCK HILFSSCHALTERBLOCK	SCHNEIDER	582 069 0
+A16	-K25	1	LC1-D258 G7	CONTACTOR SCHÜTZ	SCHNEIDER	582 047 0
+A16	-K29	1	LC1-D09 G7	CONTACTOR SCHÜTZ	SCHNEIDER	582 041 0
+A16	-K41-K42	1	LC2-K09 G7	CONTACTOR SCHÜTZ	SCHNEIDER	579 472 0
+A16	-K45	1	LC1-K09008 G7	CONTACTOR SCHÜTZ	SCHNEIDER	579 473 0
+A16	-Q29	1	GV2 RT10	CIRCUIT BREAKER LEISTUNGSSCHALTER	SCHNEIDER	579 507 0
		1	GV AN20	AUXILIARY CONTACT BLOCK HILFSSCHALTERBLOCK	SCHNEIDER	579 505 0
+A16	-S220	1	GE-S125.04	GEAR-TYPE LIMIT SWITCH GETRIEBEENDSCHALTER	STROMAG	580 005 0
+A16	-S260/-S261	2	E 215-16-11B	PUSH BUTTON DRUCKTASTER	ABB	578 553 0
+A16	-T100*	1	RSTN 100-UL-CSA 440-460-480V / 115V	TRANSFORMER TRANSFORMATOR	RIEDEL	579 568 0
		1	RSTN 100-UL-CSA 550-575-600V / 115V	TRANSFORMER TRANSFORMATOR	RIEDEL	579 569 0
+A16	-X16	1	WPE16	PE-TERMINAL SCHUTZLEITERKLEMME	WEIDMUELLER	519 518 0
		3	WDU16	TERMINAL KLEMME	WEIDMUELLER	519 513 0
		2	WDU10	TERMINAL KLEMME	WEIDMUELLER	519 512 0
		1	WPE10	PE-TERMINAL SCHUTZLEITERKLEMME	WEIDMUELLER	519 517 0
		4	A2C 2.5 PE	PE-TERMINAL SCHUTZLEITERKLEMME	WEIDMUELLER	519 634 0
		20	A2C 2.5	TERMINAL KLEMME	WEIDMUELLER	519 633 0

* to note accomplishment! / Ausführung beachten!

Date / Datum	Dept. / Abteilung	Designer / Bearbeiter	Page / Seite
07.08.2018	G-Plattform	Schnell	1/2

Drawing number

05 438 33 13 0

Stromlaufplan

BILL OF MATERIALS

Lokcat. Ort	Refer. Referenz	Qty. Anzahl	Spezifikation Typ	Description Benennung	Fabricate Hersteller	Item Code Sach-Nr.
+TR	-B275	1		LOAD SENSOR		
+TR	-M21	1		LASTSENSOR		
+TR	-M41	1		HOIST MOTOR		
+TR	-M41	1		HUBMOTOR		
+TR	-S228	1		TROLLEY MOTOR		
+TR	-S228	1		KATZFAHRMOTOR		
+TR	-S420	1		BLOCK OPERATED UPPER LIMT SWITCH		
+TR	-S420	1		ENDSCHALTER (US)		
+TR	-S420	1		TROLLEY LIMIT SWITCH		
+TR	-S420	1		KATZFAHRENSCHALTER		

Date / Datum	Dept. / Abteilung	Designer / Bearbeiter	Page / Seite
07.08.2018	G-Plattform	Schnell	2/2

power supply
Netzanschluss

control transformer
Steuertransformator

emergency hoist limit switch
Nothubendschalter

crane switch
Kranschalter

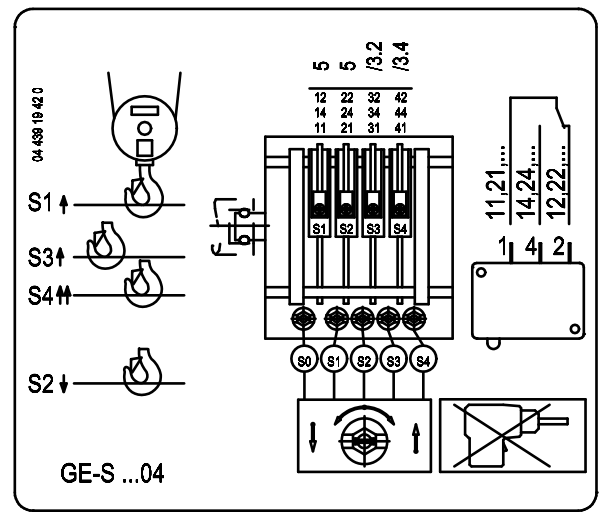
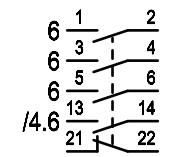
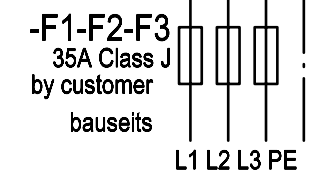
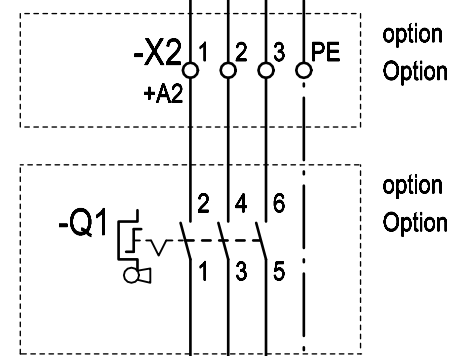
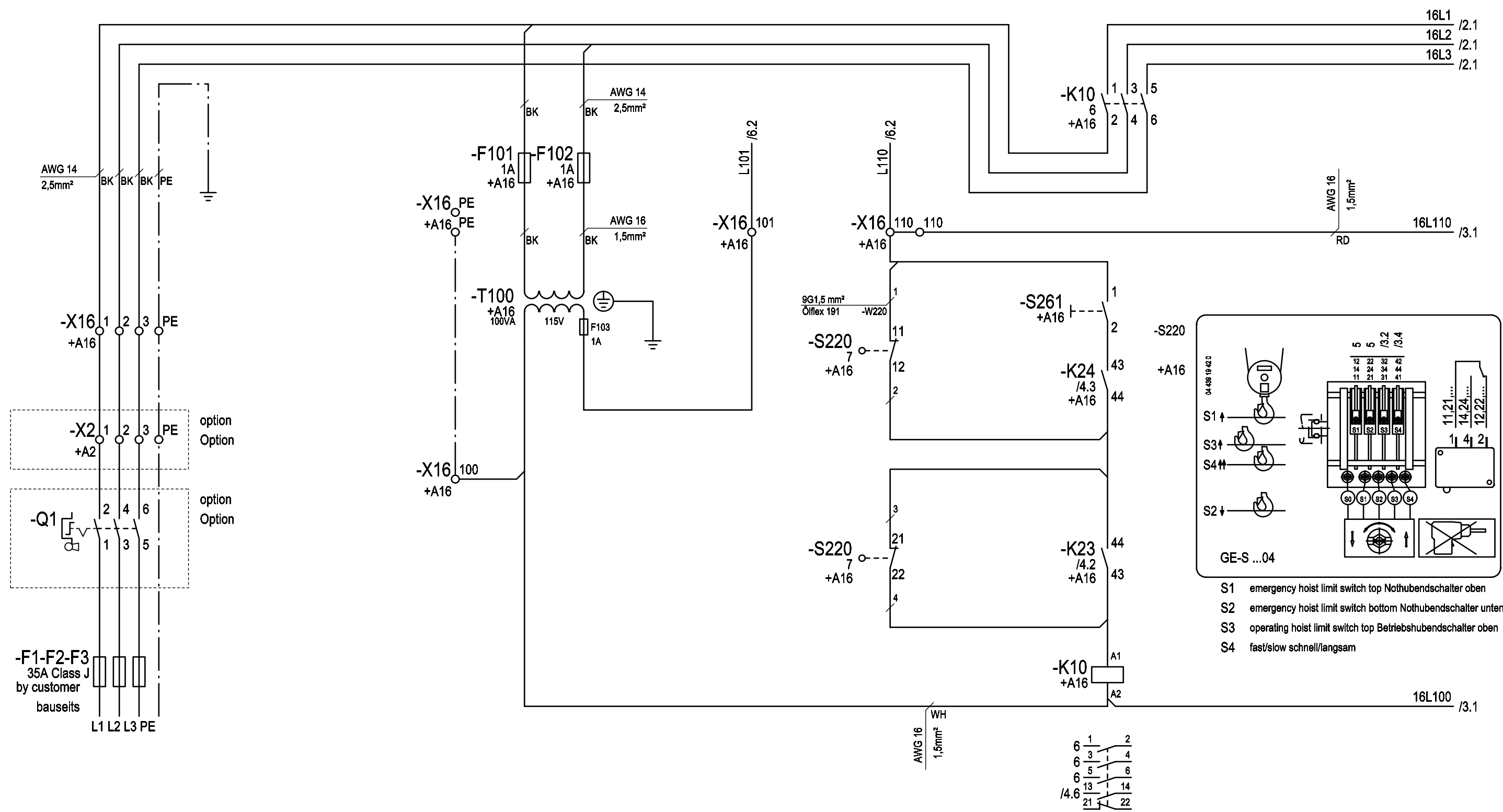

Changes	Date	Name		Date	Name
	07.08.18	Schnell	Editor	23.10.17	Huhnd.
			Proved	24.10.17	Schnell
			Release	24.10.17	Huhnd.
Rev.			Plot	06.08.2018	

Rep. by	Rep. for	Origin
---------	----------	--------

Copyright according to DIN ISO 16016	circuit diagram SH5 H71 type A SLE3 power supply
Order No.	Serial No.

=	
+	
05 438 33 13 0	Page: 1 of: 9

hoist motor
Hubmotor

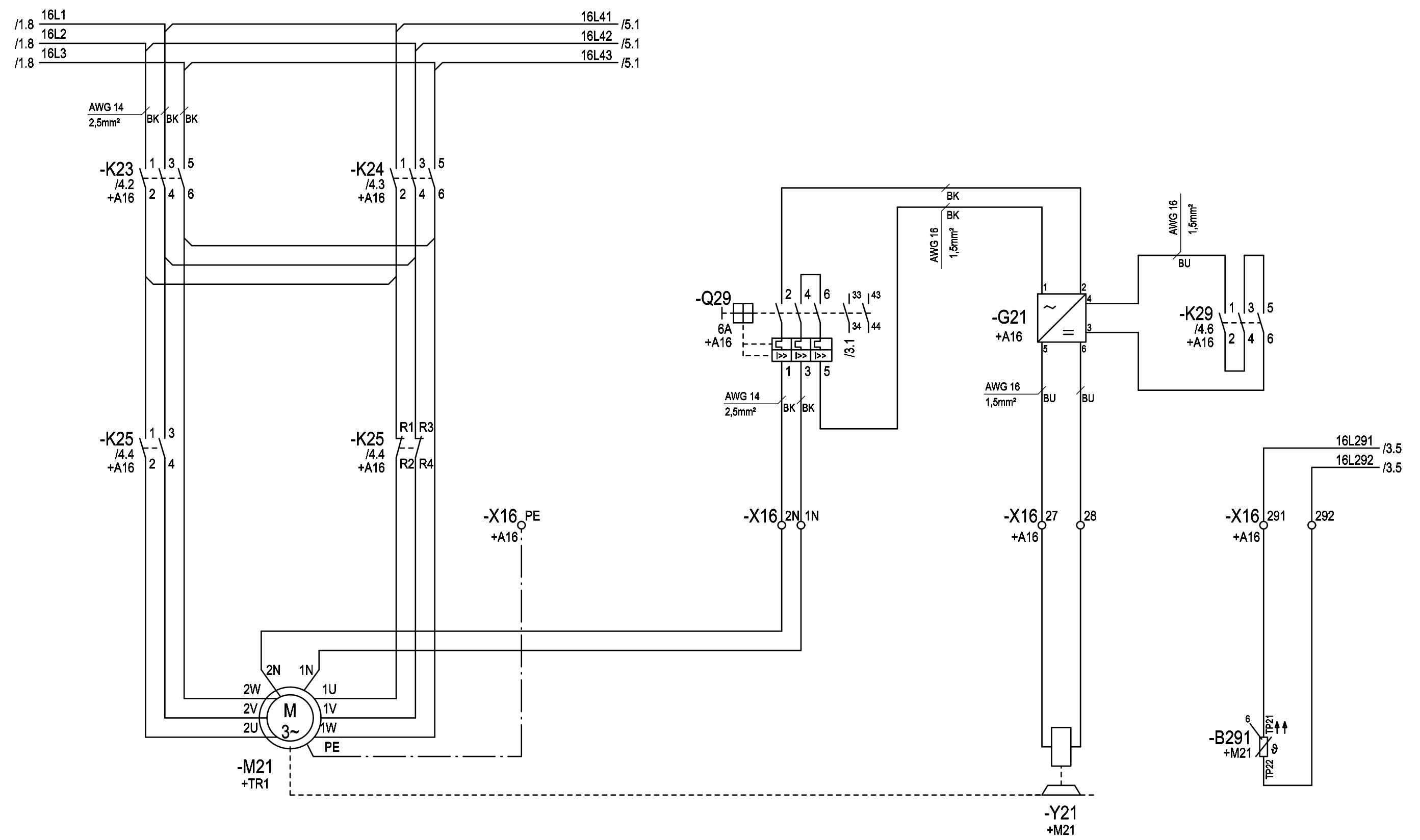

Changes	Date	Name	Date	Name
	07.08.18	Schnell	23.10.17	Huhnd.
			24.10.17	Schnell
			24.10.17	Huhnd.

Rev.		Plot	06.08.2018	Rep. by		Rep. for		Origin	
------	--	------	------------	---------	--	----------	--	--------	--

Copyright according to	circuit diagram SH5 H71 type A SLE3 hoisting
DIN ISO	
16016	

Order No.	Serial No.	05 438 33 13 0

=	
+	
Page: 2	
of: 9	

hoisting
heben

lowering
senken

fast
schnell

temperature / load monitoring
Temperatur- / Lastüberwachung

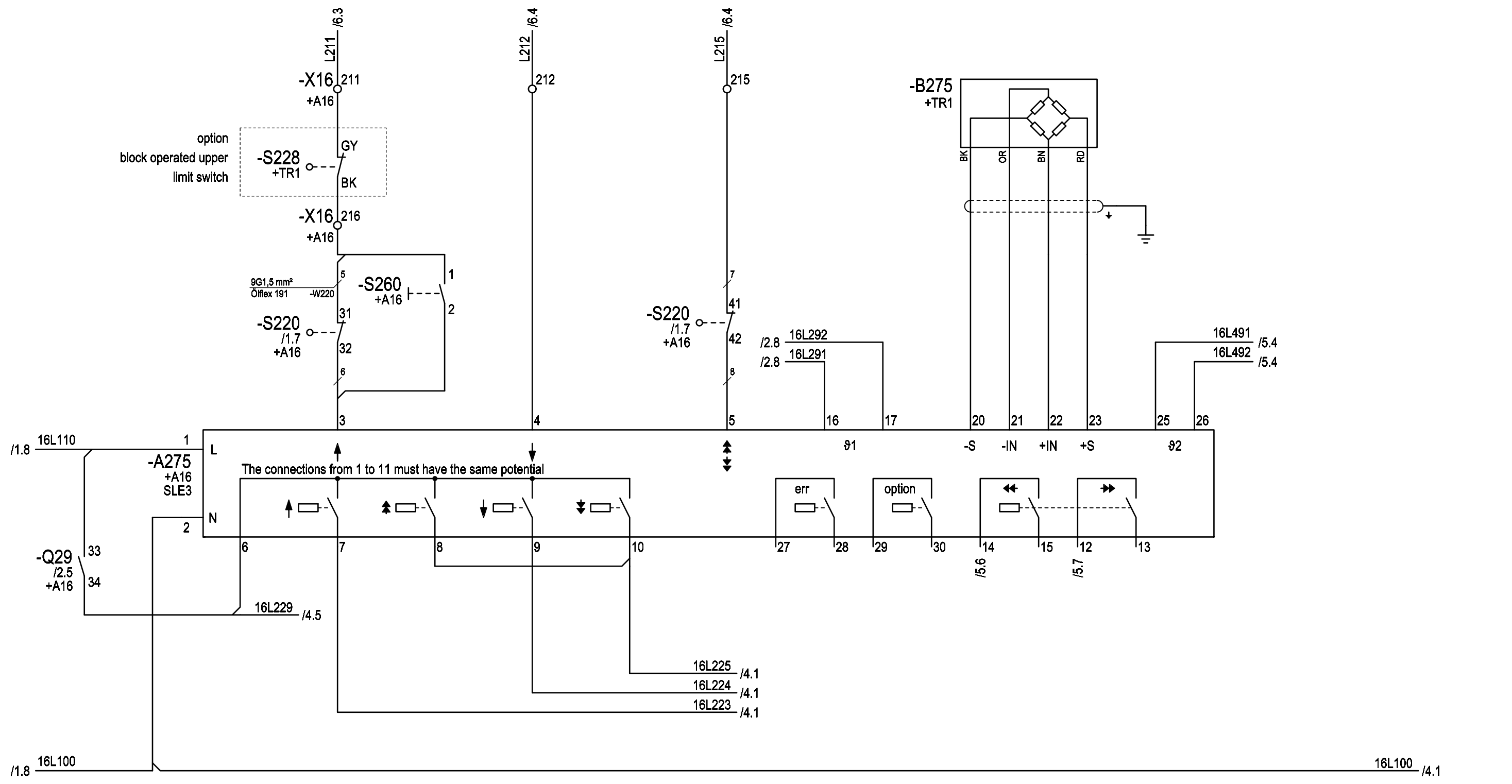

Changes	Date	Name	Date	Name
	07.08.18	Schnell	23.10.17	Huhnd.
			24.10.17	Schnell
			24.10.17	Huhnd.

Rev.		Plot	06.08.2018	Rep. by		Rep. for		Origin	
------	--	------	------------	---------	--	----------	--	--------	--

Copyright according to DIN ISO 16016	circuit diagram SH5 H71 type A SLE3 hoisting	=
		+
Order No.	Serial No.	05 438 33 13 0
		Page: 3 of: 9

hoisting
heben

lowering
senken

fast
schnell

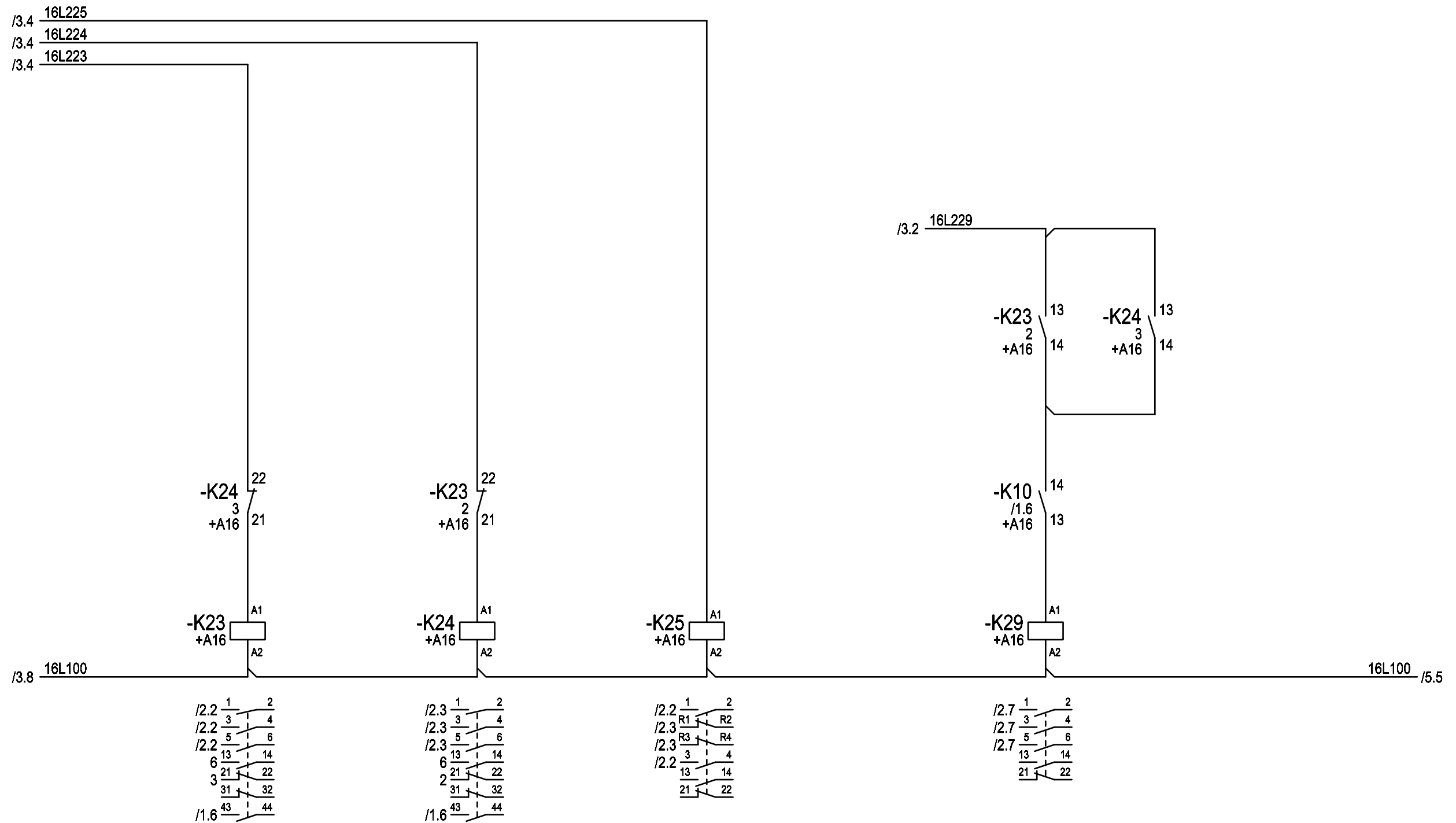

Rev.	Changes	Date	Name	Date	Name
		07.08.18	Schnell	23.10.17	Huhnd.
				24.10.17	Schnell
				24.10.17	Huhnd.
				06.08.2018	

Rep. by	Rep. for	Origin
---------	----------	--------

Copyright according to DIN ISO 16016	circuit diagram SH5 H71 type A SLE3 hoisting
Order No.	Serial No.

=	
+	
05 438 33 13 0	Page: 4 of: 9

cross travel motor
Katzfahrmotor

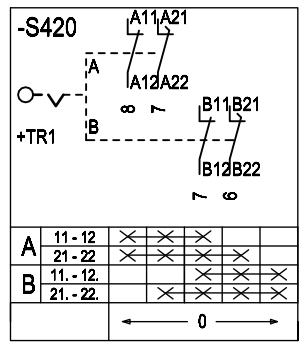
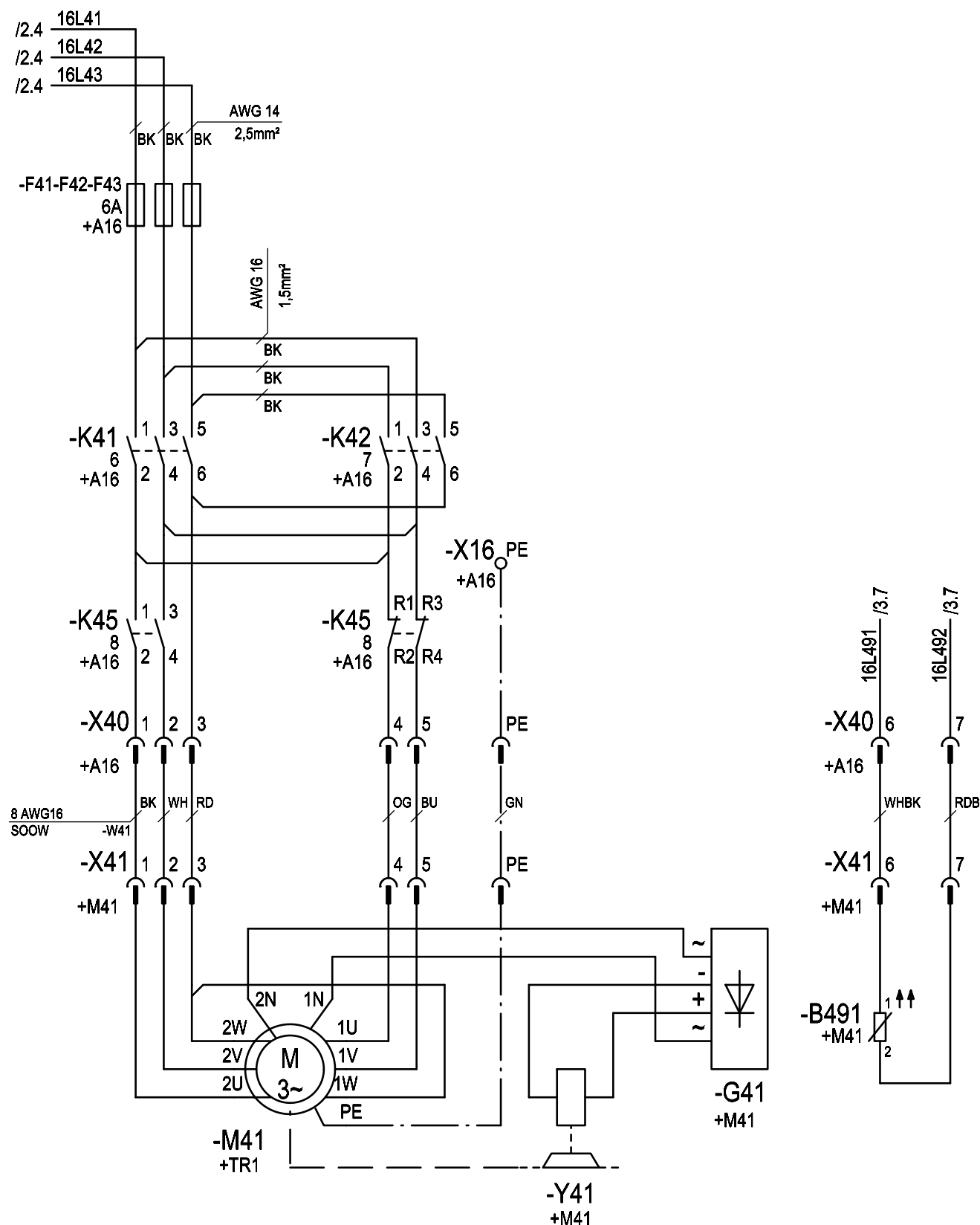

Attention!
with double-rail crab: change contact A21-A22 and B21-B22
Bei Obergurttfahrwerken: Kontakte A21-A22 und B21-B22 tauschen

left links
right rechts

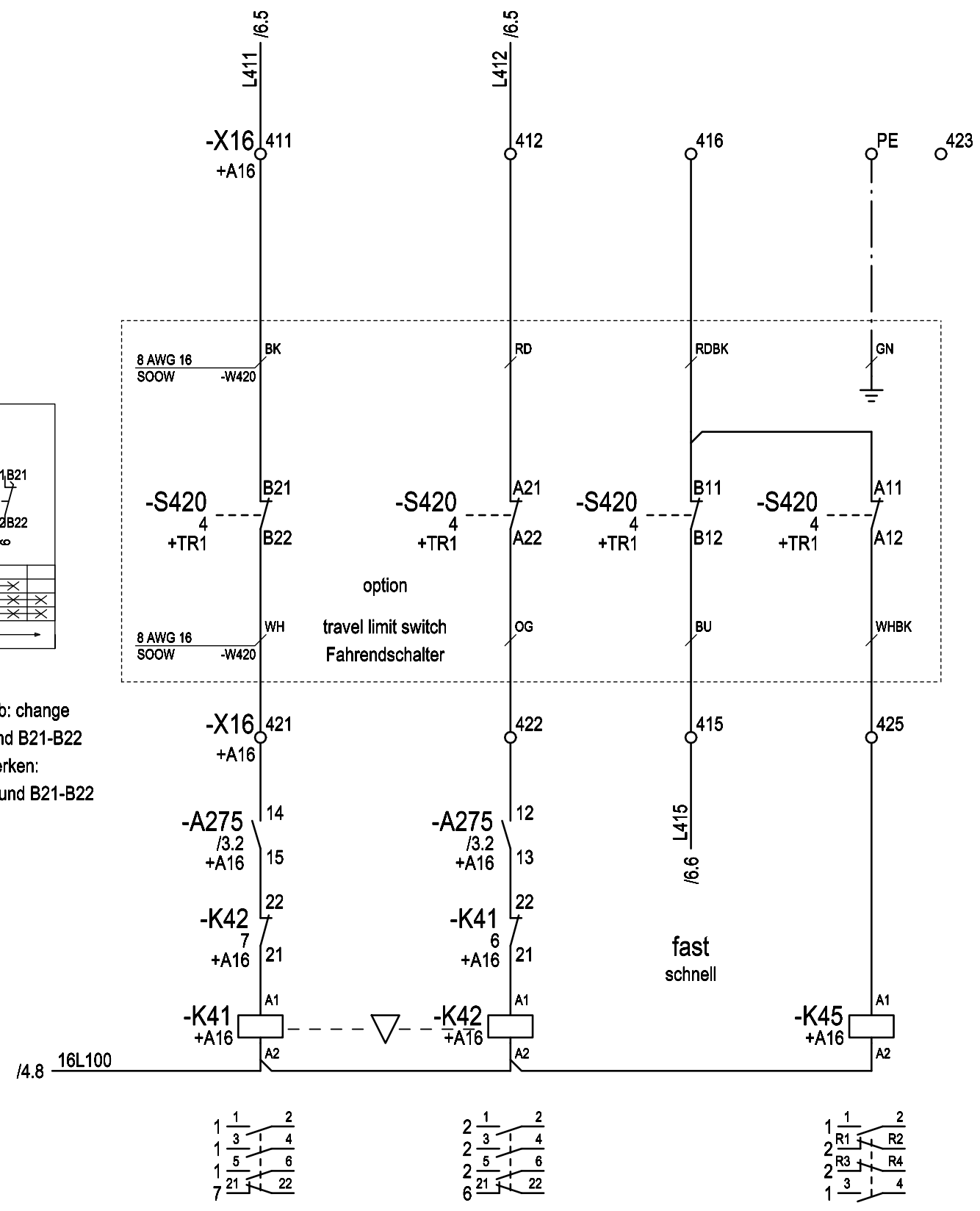

Changes	Date	Name	Date	Name
	07.08.18	Schnell	23.10.17	Huhnd.
			24.10.17	Schnell
			24.10.17	Huhnd.

Rev.	Plot	06.08.2018	Rep. by	Rep. for	Origin
------	------	------------	---------	----------	--------

Copyright according to DIN ISO 16016	circuit diagram SH5 H71 type A SLE3 trolley
Order No.	Serial No.

=	
+	
05 438 33 13 0	Page: 5 of: 9

option

hoisting gear
Hubwerk

trolley traveling gear
Katzfahrwerk

emergency stop
Not-Halt

hoisting
heben

lowering
senken

fast
schnell

left
links

right
rechts

fast
schnell

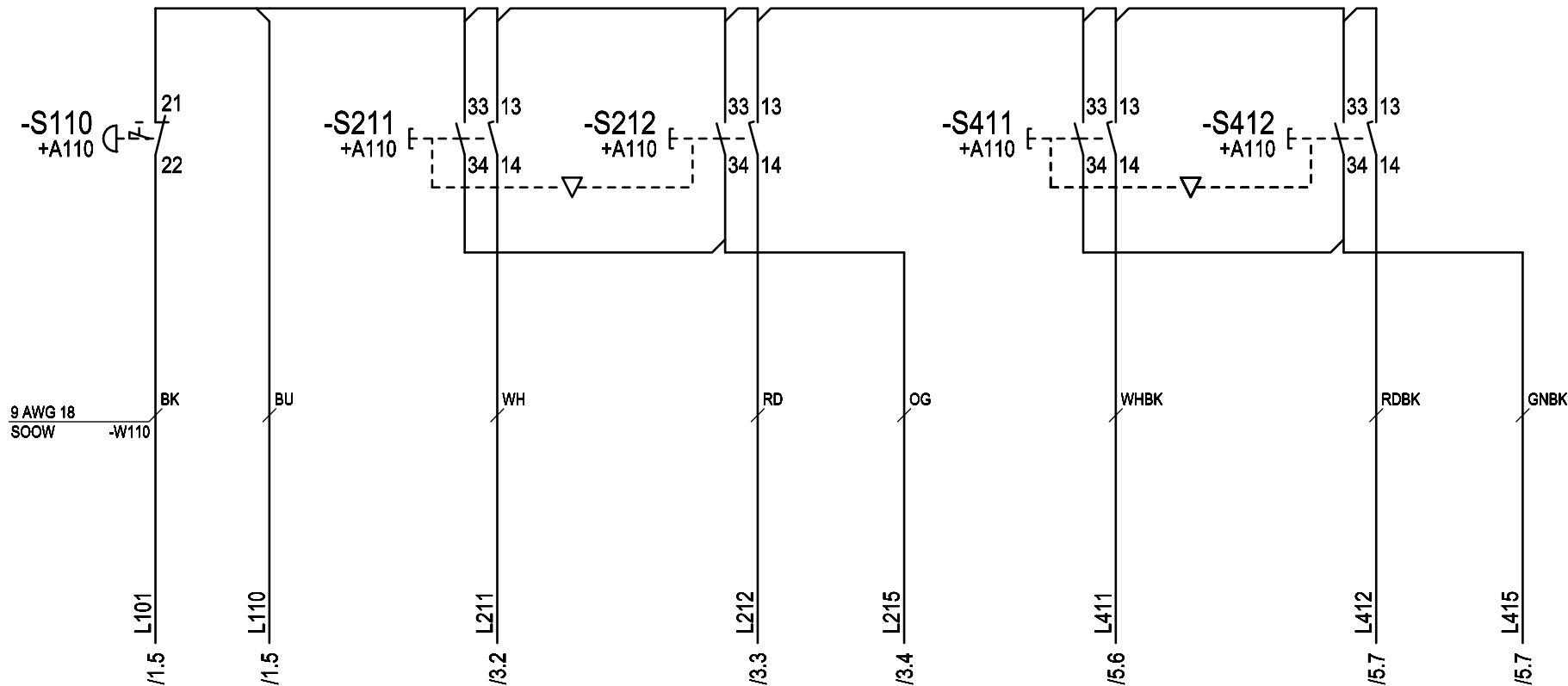

Rev.	Changes	Date	Name	Date	Name
		07.08.18	Schnell	23.10.17	Huhnd.
				24.10.17	Schnell
				24.10.17	Huhnd.

Plot	06.08.2018	Rep. by	Rep. for	Origin
------	------------	---------	----------	--------

Copyright according to DIN ISO 16016	circuit diagram SH5 H71 type A SLE3 control pendant	Order No.	Serial No.
--------------------------------------	---	-----------	------------

=	
+	
05 438 33 13 0	Page: 6 of: 9

GK SH5

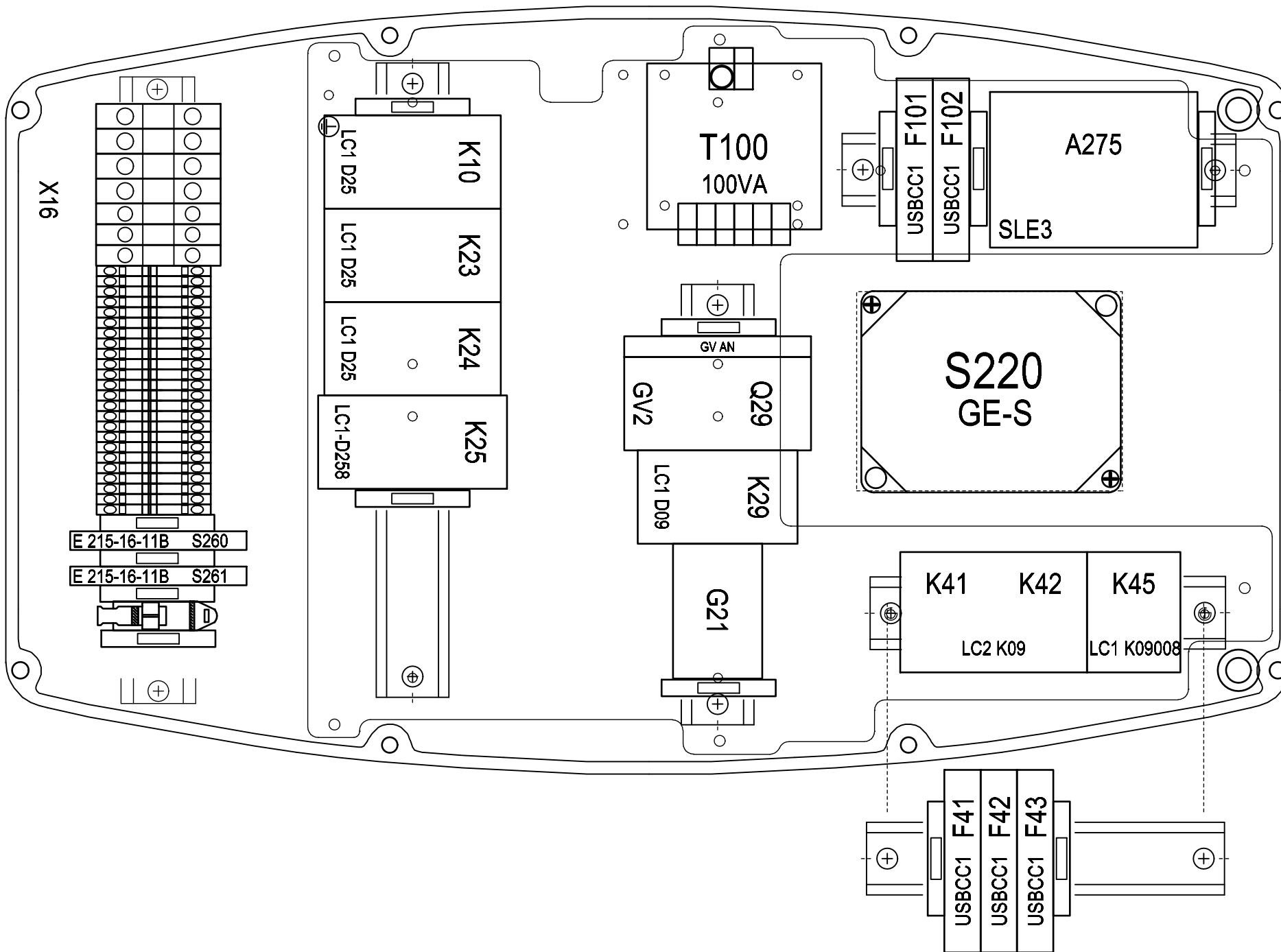

Changes	Date	Name		Date	Name
	07.08.18	Schnell	Editor	23.10.17	Huhnd.
			Proved	24.10.17	Schnell
			Release	24.10.17	Huhnd.
Rev.			Plot	06.08.2018	

Rep. by	Rep. for	Origin
---------	----------	--------

Copyright according to DIN ISO 16016

location diagram
SH5 H71 type A SLE3
+A16

Order No. Serial No.

=	
+	
05 438 33 13 0	Page: 8 of: 9

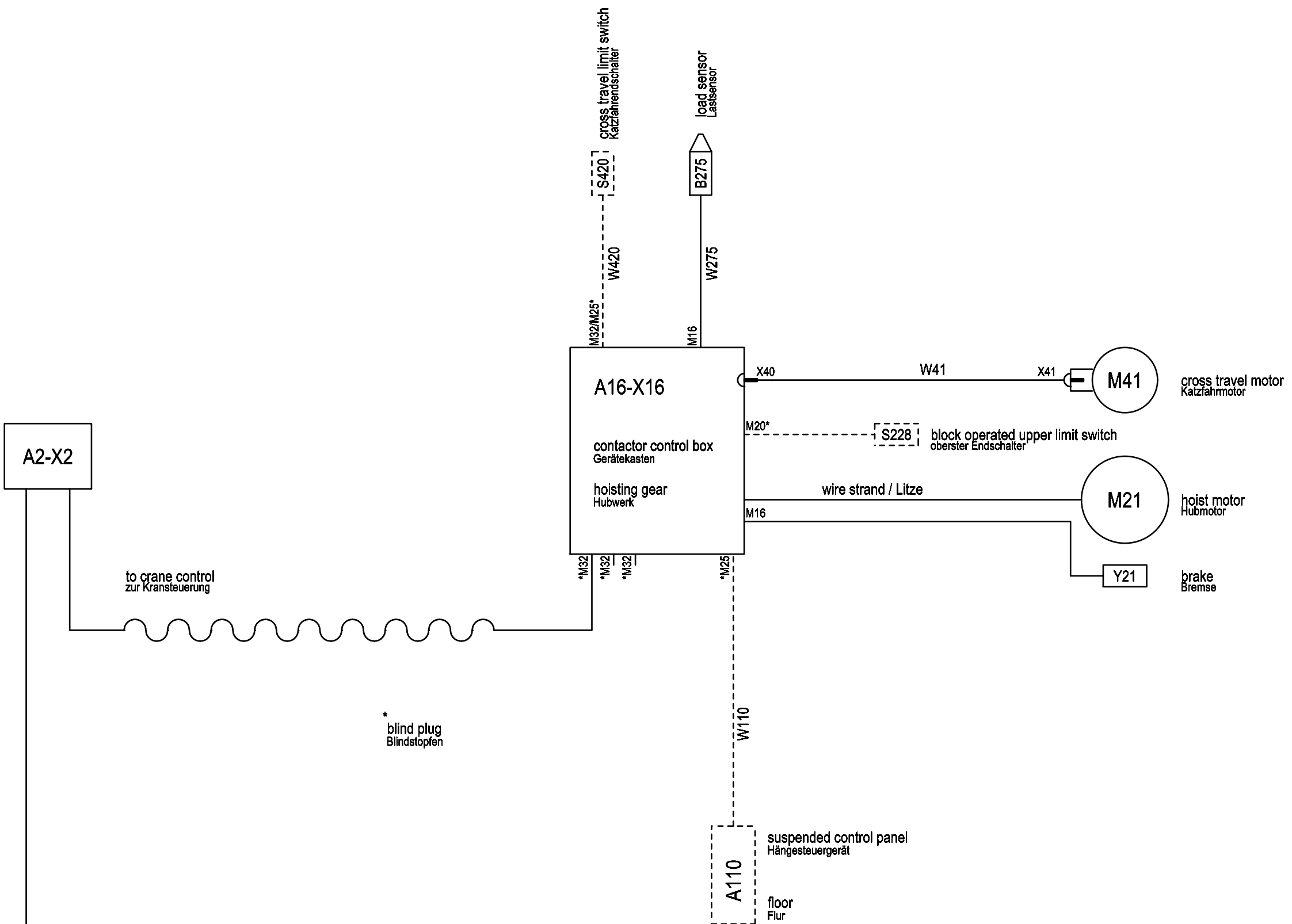

to crane control
zur Kransteuerung

* blind plug
Blindstopfen

Rev.	Changes	Date	Name	Date	Name
		07.08.18	Schnell	23.10.17	Huhnd.
			Proved	24.10.17	Schnell
			Release	24.10.17	Huhnd.
			Plot	06.08.2018	

Rep. by	Rep. for	Origin
---------	----------	--------

Copyright according to DIN ISO 16016	cable diagram SH5 H71 type A SLE3
Order No.	Serial No.

=	
+	
05 438 33 13 0	Page: 9 of: 9